

El Niño

Order N°: 02094

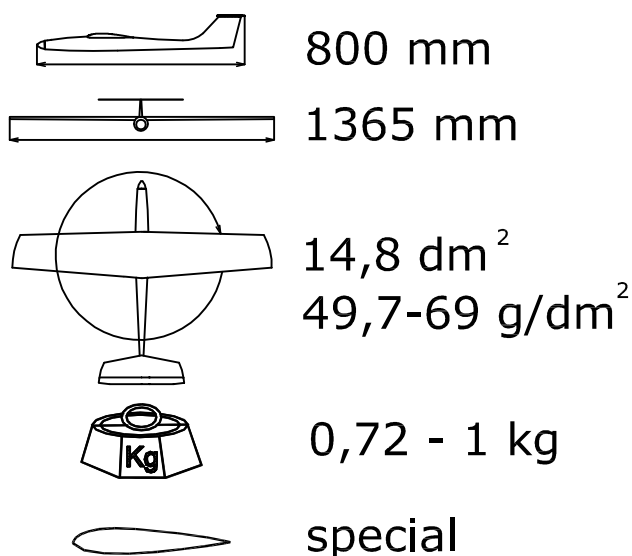

HOLLOW MOLDED FIBERGLASS SPEED AIRPLANE



Radio system you'll need :

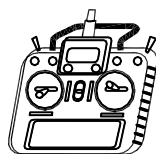

3-4-channel
with
3 servos

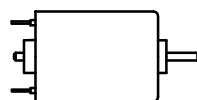

Mega ACn 16/15/3
Mega ACn 16/25/2

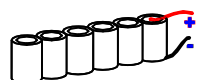

3-5S LiPo 2Ah

*Není-li uvedeno jinak, všechny
neoznačené míry jsou v milimetrech*
UNLES STATED, ALL DIMENSIONS
ARE IN MILIMETERS

Manufactured by:

TOPMODEL CZ

679 05 HABRŮVKA 100 - CZECH REPUBLIC
www.topmodelcz.cz
e-mail: info@topmodelcz.cz

GB - USA Parts list

Part #	Part name	Material, dimensions	Loose	In bag
	building instruction		01	-
1	fuselage	fibreglass	01	-
1-1	engine mount	fibreglass 2 mm	-	01
1-2	servo tray	plywood 4 x 18 x 36 mm	-	01
2	wing	fibreglass hollow molded	01	-
2-2	wing fixing screw	screw M 4 x 10 mm	-	01
2-21	centering pin	fibreglass Ø 4 x 56 mm	-	01
2-3	nut	aluminium M4	-	01
2-31	nut mount	plywood 3 x 20 x 37 mm	-	01
2-41	wing servo cover	fibreglass	-	02
2-5	aileron pushrod	piano wire Ø 1,2 x 60 mm	-	02
2-6	lock pushrod	plastic Ø 2/1	-	01
2-8	aileron horn	fibreglass plate 1 mm	-	02
3	horizontal stabilizer	fibreglass hollow molded	01	-
3-2	fixing elevator	carbon Ø 1,5 x 10 mm	-	02
3-5	elevator link	plastic Ø 0,8 x 570 mm piano wire Ø 1,2 x 140 mm	01+01	-
3-6	threaded link	MPJ 2764	-	01
3-8	elevator horn	fibreglass plate 1 mm	-	01
7	stickers		02	

RECOMMENDED EQUIPMENT:

		Pieces		Item No. www.topmodelcz.cz
Transmitter	4 channel			
Receiver	5 channel			
Servo	SS1816	2	ailerons	0201816
	Pico servo PS1616	1	elevator	0201616
Motor	Mega ACn 16/15/3	1	for recreational flying	20161503
Controller:	XREG 60	1	for 3S LiPo battery	099REG60
	SPIN 75 OPTO	1	for 4-5S LiPo battery	SPIN 75 OPTO
RX battery	4,8V	1	for OPTO controller	
Spinner:	Alu spinner for standard e. props Ø 30	1		7020
Propeller:	CAM SPEED PROP 12x12 cm	1		1361.12.12

ATTENTION:

This model construction kit is not a toy and is not suitable for children under the age of 14.

Incorrect use of this material could cause material damage or person injury. You are fully responsible for your actions when you use this model.

Fly at a safe distance from occupied zones. Be sure that no one else is using the same frequency as you.

CZ Seznam dílů

Položka	Název dílu	Materiál, rozměr	Volně / ks	Balíček / ks
	montážní návod		01	-
1	trup	laminát	01	-
1-1	motorová přepážka	sklotextit 2 mm	-	01
1-2	držák serva výškovky	překližka 4 x 18 x 36	-	01
2	křídlo	laminát	01	-
2-2	uchycení křídla	šroub M 4 x 10 mm	-	01
2-21	aretační kolík	laminát Ø 4 x 56 mm	-	01
2-3	uchycení křídla	matice AL. M4	-	02
2-31	podložka matice	překližka 3 x 20 x 37	-	01
2-41	krytka serva	laminát	-	02
2-5	táhlo křídélka	drát Ø 1,2 mm l = 60 mm	-	02
2-6	zajištění táhla	plast Ø 2/1	-	01
2-8	páka křídélka	sklotextit 1 mm	-	02
3	výškovka	laminát	01	-
3-2	aretační výškovky	uhlík Ø 1,5	-	02
3-5	táhlo výškovky	plast Ø2 x 540mm, ocel Ø 0,8 x 570 mm	01 + 01	-
3-7	koncovka táhla	MPJ 2764	-	01
3-8	páka VOP	sklotextit 1 mm	-	01
7	obtisky		02	

DOPORUČENÉ PŘÍSLUŠENSTVÍ :

		kusů		objednací číslo www.topmodelcz.cz
vysílač	4 kanál			
přijímač	5 kanál			
servo	Servo SS1816	2	křídélka	0201816
	Servo PS1616	1	výškovka	0201616
motor	Mega ACn 16/15/3	1	pro rekreační létání	20161503
regulátor	XREG 60	1	pro 3S LiPo	099REG60
	SPIN 75 OPTO	1	pro 4 – 5S LiPo	SPIN 75 OPTO
přijímačové akumulátory	4,8V	1	pro OPTO regulátory	
kužel	Kužel Ø 30 mm	1		7020
vrtule	CAM SPEED PROP 12x12	1		1361.12.12

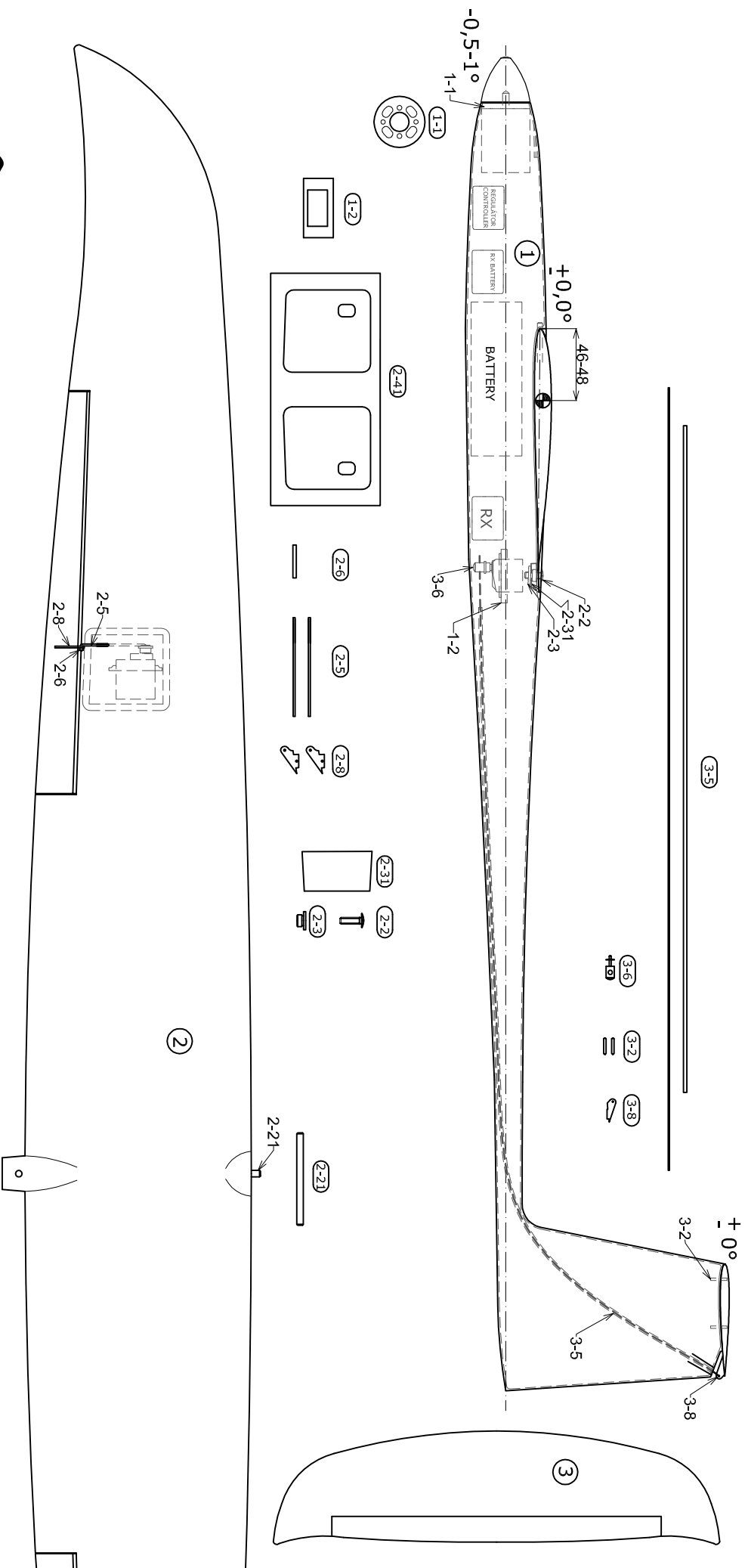

Elf Niño

© III. 2011 TOPMODEL CZ Manufactured by TOPMODEL CZ s.r.o. - Made in the Czech Republic

Výkres není v měřítku - Not scale !!!

pro serva křídálek
for ailerons servo
~ 320 mm

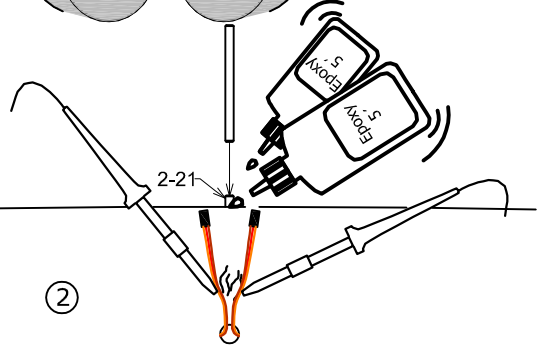
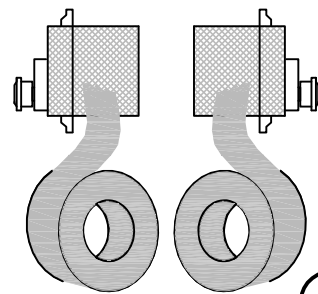
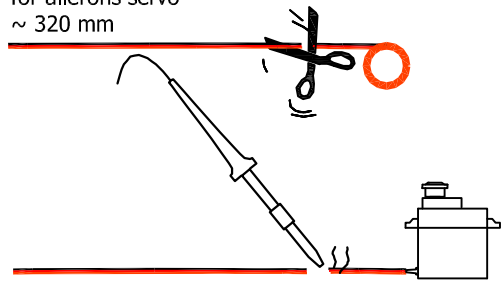
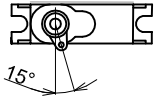
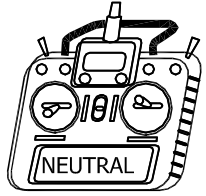

SPODNÍ STRANA
BOTTOM

②

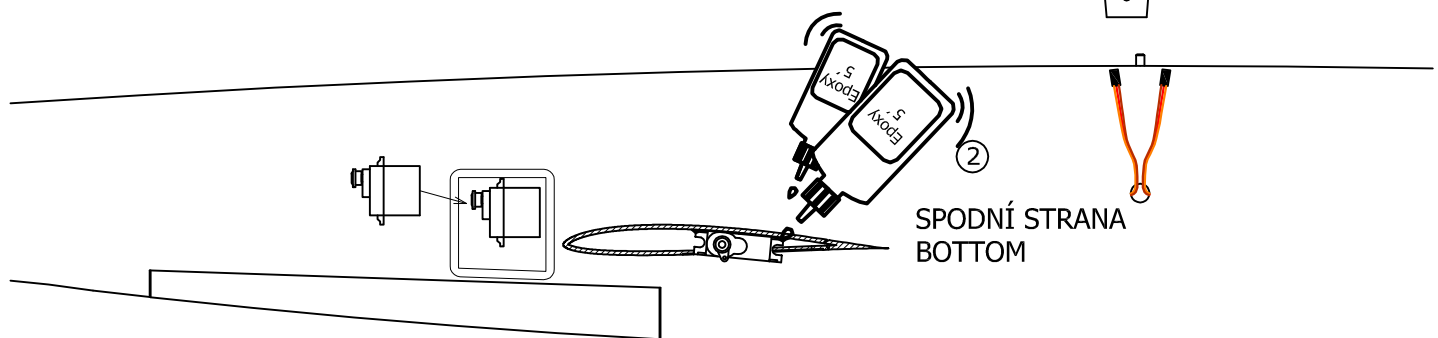
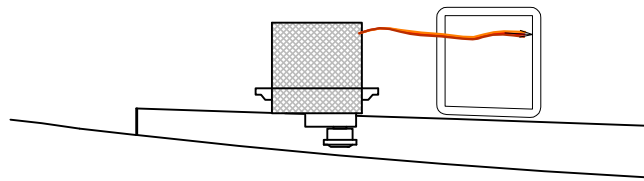

SPODNÍ STRANA
BOTTOM

②

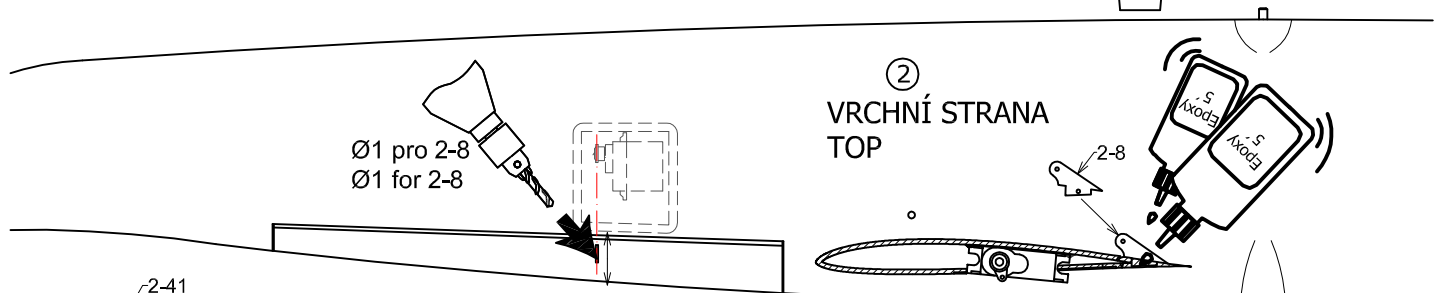

VRCHNÍ STRANA
TOP

②

Ø1 pro 2-8
Ø1 for 2-8

A = A'

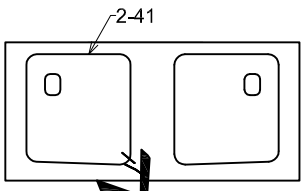

Ø1,5 pro 2-5
Ø1,5 for 2-5

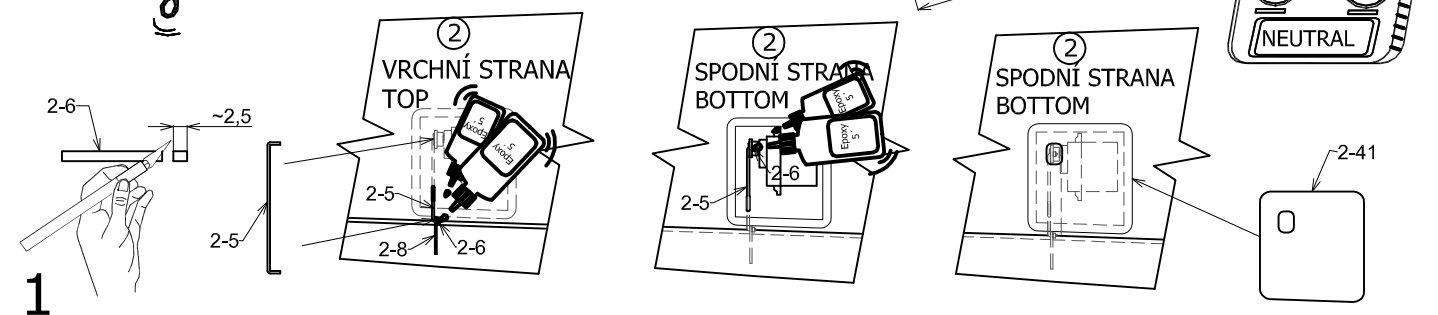

VRCHNÍ STRANA
TOP

SPODNÍ STRANA
BOTTOM

SPODNÍ STRANA
BOTTOM

1

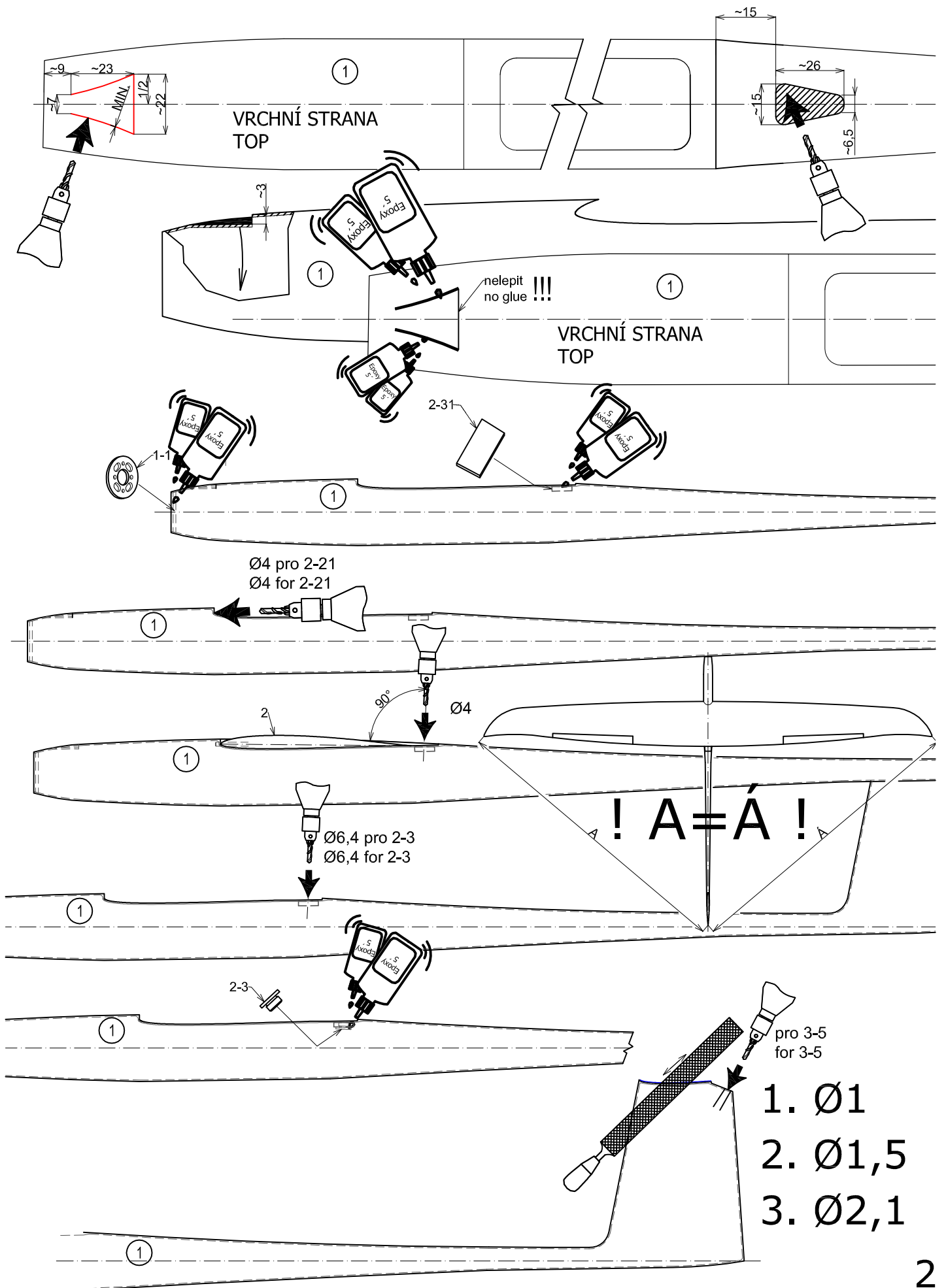

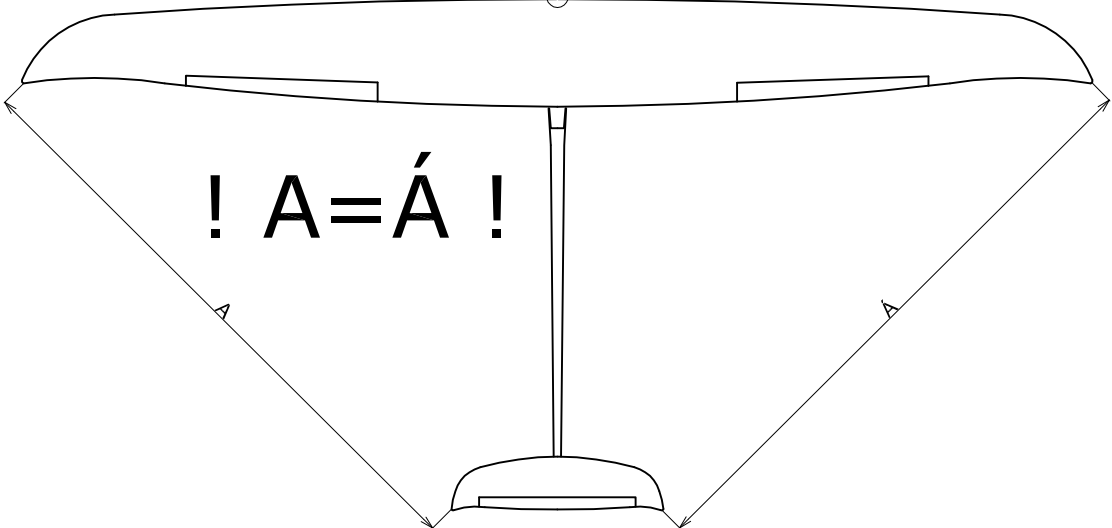
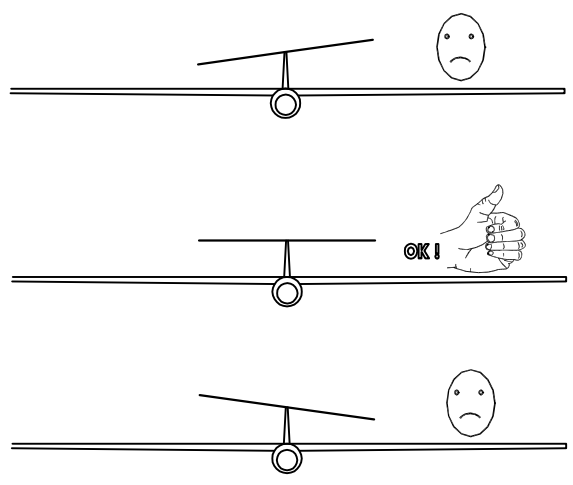
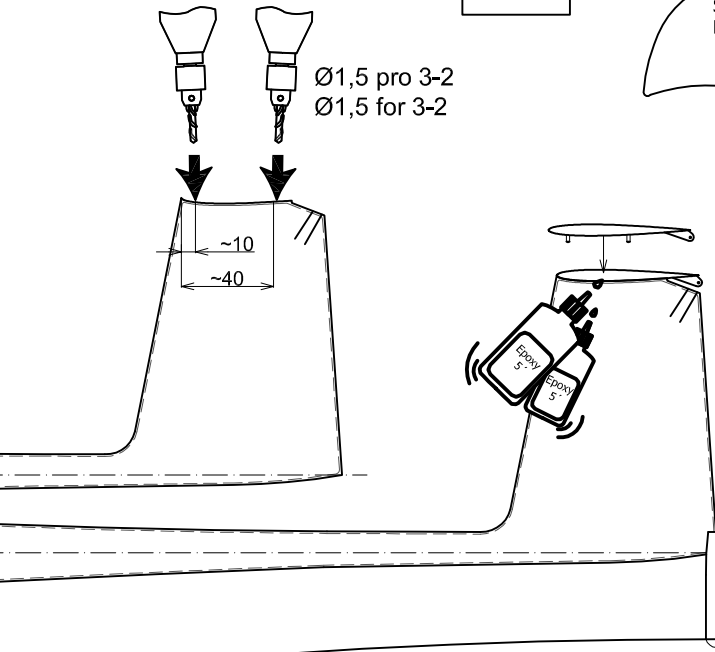
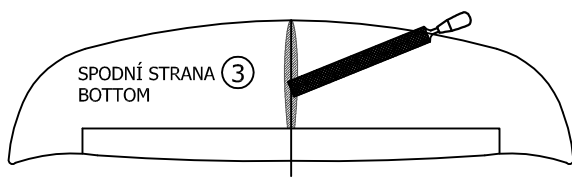
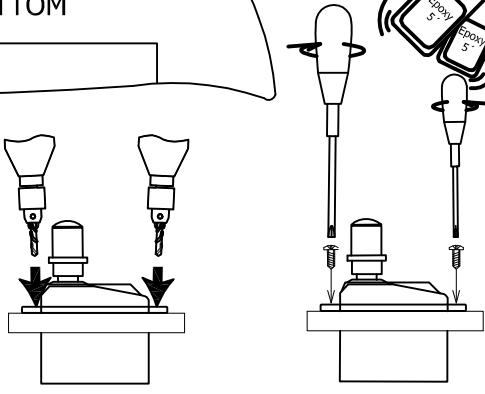
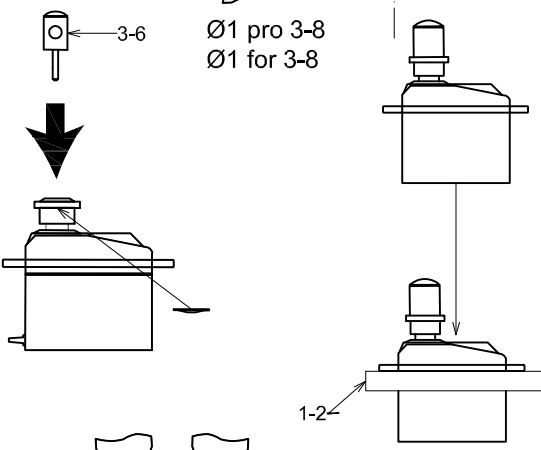
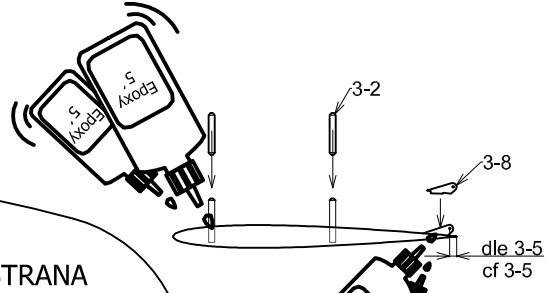
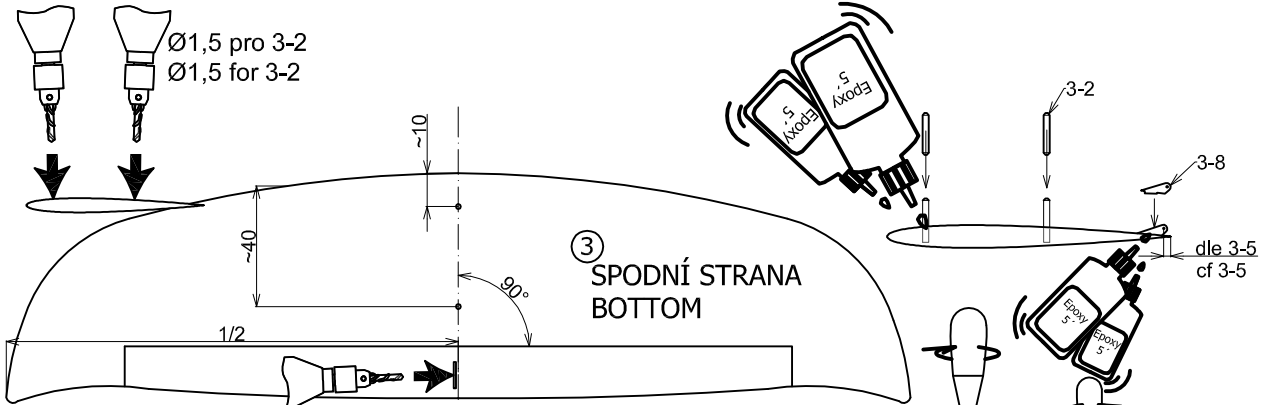

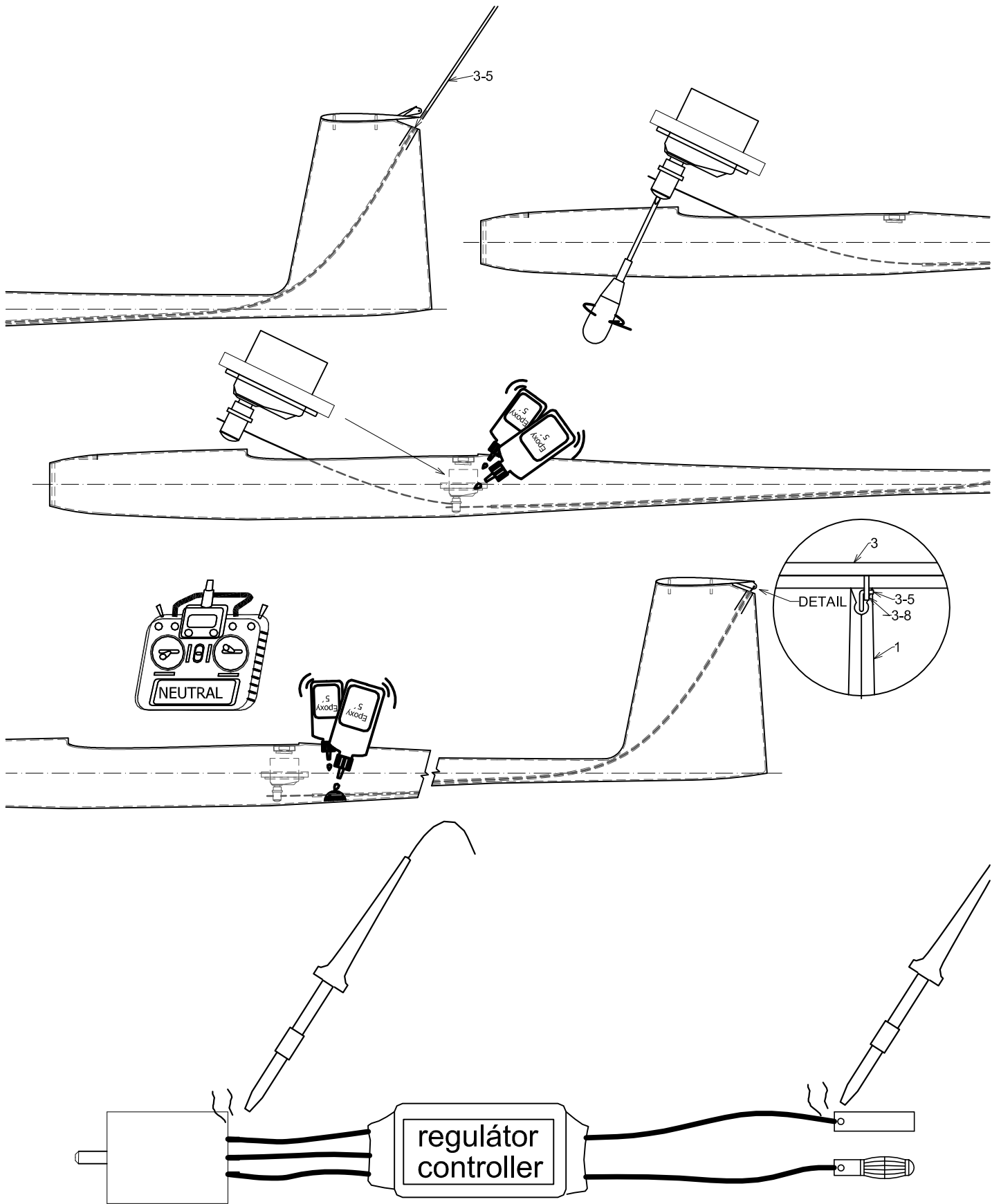

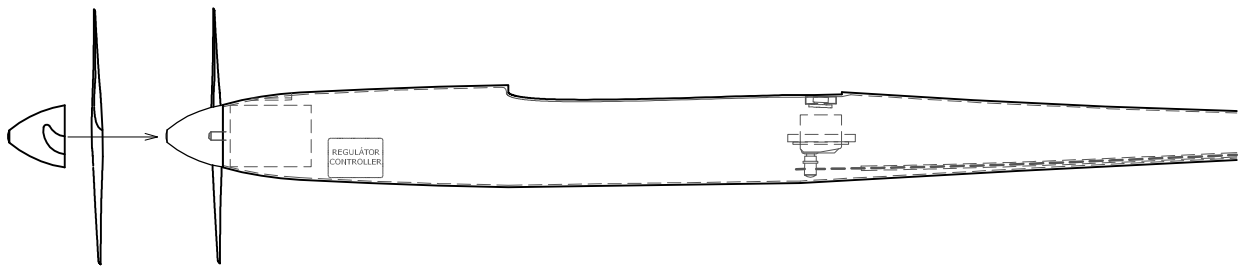
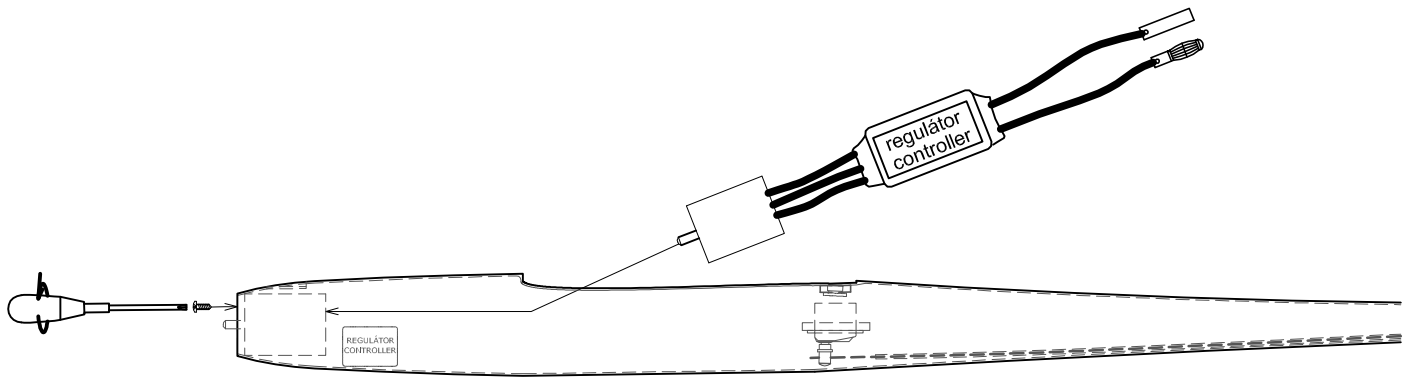

Pro 3S LiPo For 3S LiPo

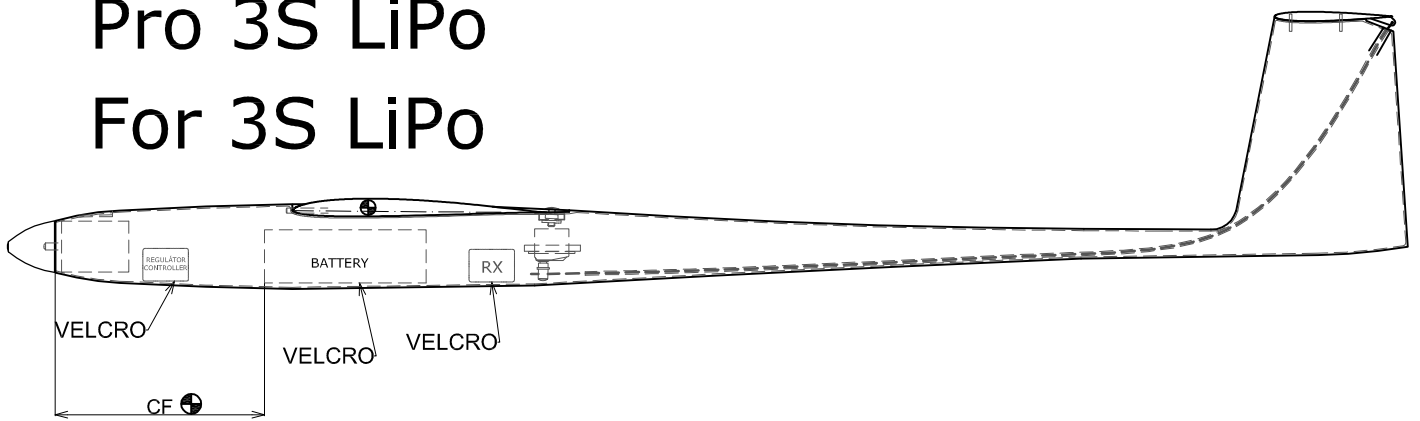

Pro 4-5S LiPo For 4-5S LiPo

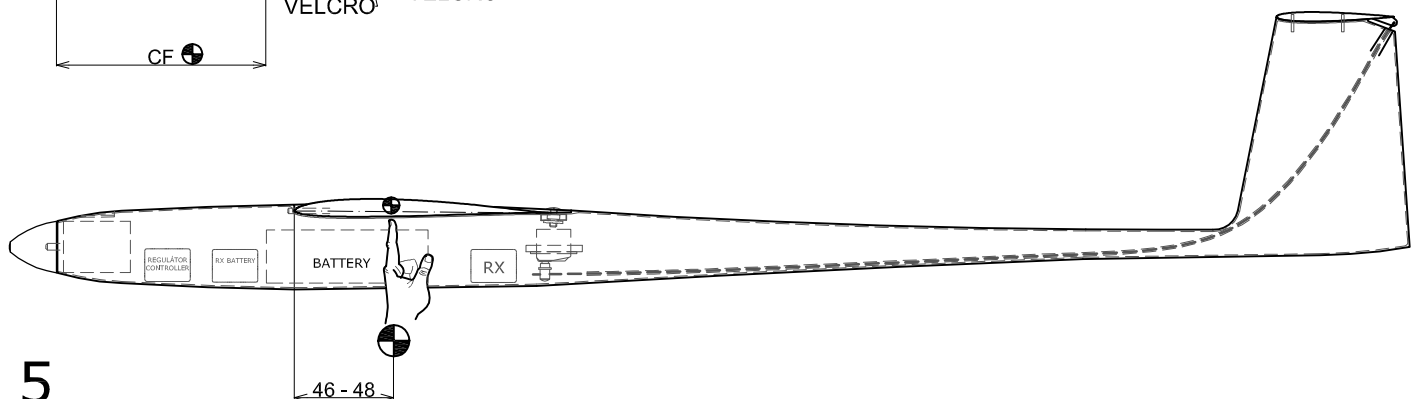
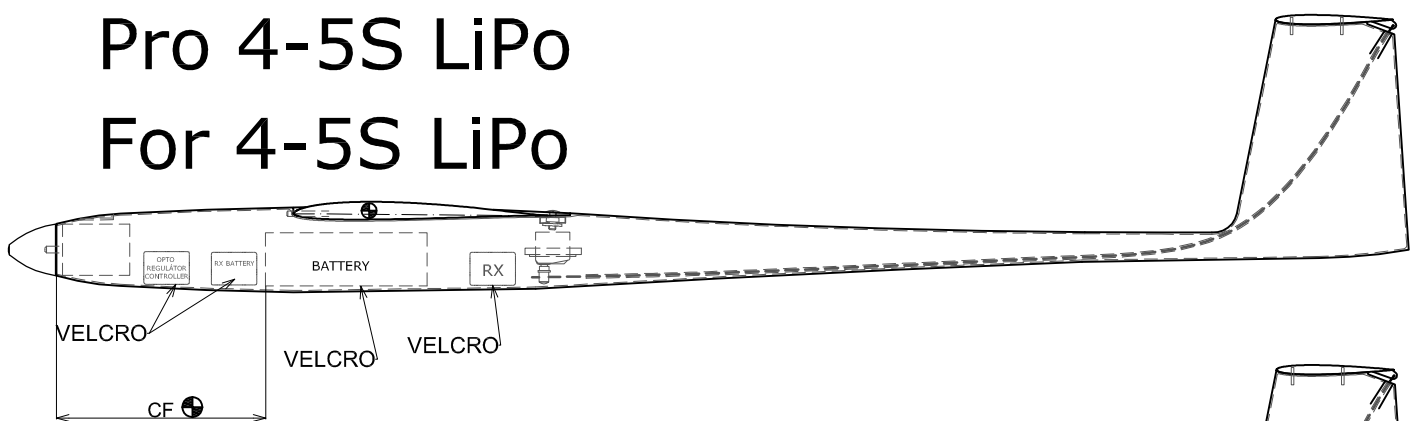

Power 0-50% / 50-100%

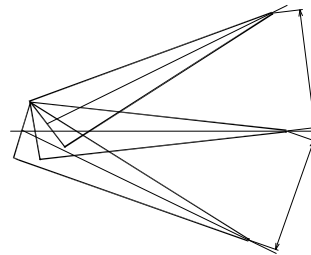
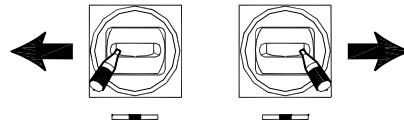
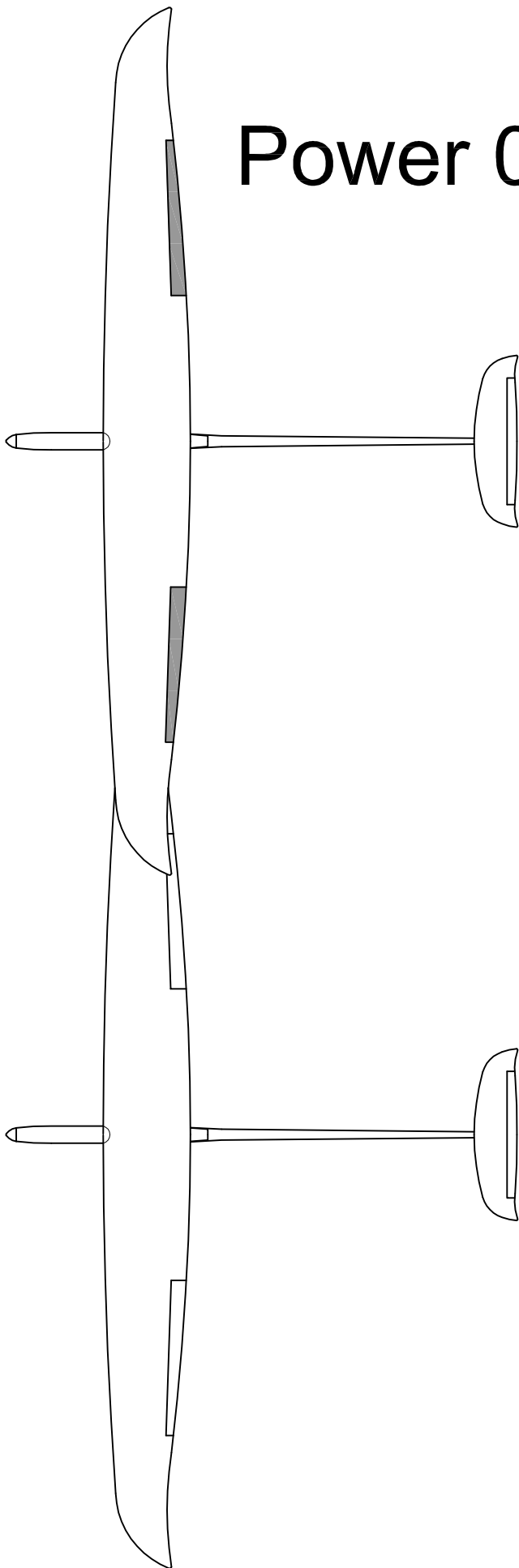

5,5 / 3,5mm
EXPO 25%
4,5 / 2,5mm



3 / 2,5mm
EXPO 30%
2,5 / 1,5mm