



P51- MUSTANG 6000 SCALE 1:5 ¼ ARF

SPECIFICATION

- **Wingspan:** 2190mm (86.2 in)
- **Length:** 1907mm (75 in)
- **Flying weight:** 9000 -12000 gr
- **Wing area:** 92 dm²
- **Wing loading:** 98g/dm²
- **Wing type:** Naca airfoils
- **Retract gear type:** Air-retract With CNC Suspension Metal Struts (included)
- **Spinner size:** P51 Mustang type, aluminum plate 115mm (included)
- **Radio:** 6 channel minimum (not included)
- **Servo:** 9 standard hi-torque servo: 2 aileron; 2 flap; 2 elevator; 1 rudder; 1 retract; 1 throttle (not included)
- **Recommended receiver battery:** 6.0V 2400/2600mAh NiMH (2) (not included)
- **Servo mount:** 21 mm x 42 mm
- **Propeller:** suit with your engine

- **Engine:** 50-60 CC gas engine (two stroke) (not included)
- **Motor:** brushless outrunner 2600-3000 W, 190 KV (not included)
- **Gravity CG:** 190 mm (7,48 in) Back from the leading edge of the wing, at the fuselage
- **Control throw Ailerons:** Low: 15mm up/down, 10% expo; High: 20mm up/down, 10% expo
- **Control throw Elevators:** Low: 15mm up/down, 12% expo; High: 20mm up/down, 12% expo
- **Control throw Rudder:** Low: 40mm right/left, 15% expo; High: 60mm right/left, 15% expo
- **Control throw Flaps:** Mid: 25mm down; Landing: 35mm down
- **Experience level:** Intermediate
- **Plane type:** Scale Military

RECOMMENDED MOTOR AND BATTERY SET UP

- **Motor:** hacker brushless A60 (not included)
- **Propeller:** 22x12 APC E (not included)
- **Lipo cell:** 12 cells / 5000 – 6000mAh (not included)
- **Esc:** 120-160A / HV (not included)

TOOLS AND SUPPLIES NEEDED

- Medium C/A glue
- 30 minute epoxy
- 6 minute epoxy
- Hand or electric drill
- Assorted drill bits
- Modeling knife
- Straight edge ruler
- 2 bender plier
- Wire cutters
- Masking tape
- Thread lock
- Paper towels
- Rubbing alcohol

SUGGESTION

To avoid scratching your new airplane, do not unwrap the pieces until they are needed for assembly. Cover your workbench with an old towel or brown paper, both to protect the aircraft and to protect the table. Keep a couple of jars or bowls handy to hold the small parts after you open the bag.

NOTE:

1. Please trial fit all the parts. Make sure you have the correct parts and that they fit and are aligned properly before gluing! This will assure proper assembly. The P51- MUSTANG 60CC SCALE 1:5 ¼ ARF is hand made from natural materials, every plane is unique and minor adjustments may have to be made. However, you should find the fit superior and assembly simple.
2. The painted and plastic parts used in this kit are fuel proof. However, they are not tolerant of many harsh chemicals including the following: paint thinner, C/A glue accelerator, C/A glue debonder and acetone. Do not let these chemicals come in contact with the colors on the covering and the plastic parts.

SAFETY PRECAUTION:

- This is not a toy.
- Be sure that no other flyers are using your radio frequency.
- Do not smoke near fuel.
- Store fuel in a cool, dry place, away from children and pets.
- Wear safety glasses.
- The glow plug clip must be securely attached to the glow plug.
- Do not flip the propeller with your fingers.
- Keep loose clothing and wires away from the propeller.
- Do not start the engine if people are near. Do not stand in line with the side of the propeller.
- Make engine adjustments from behind the propeller only. Do not reach around the spinning propeller.

PREPARATIONS

Remove the tape and separate the ailerons from the wing and the elevators from the stab. Use a covering iron with a covering sock on high heat to tighten the covering if necessary. Apply pressure over sheeted areas to thoroughly bond the covering to the wood.

**INSTALLING THE AILERON AND FLAP SERVOS**

1. Install the rubber grommets and brass eyelets onto the aileron servo.
2. Using a modeling knife, remove the covering from over the pre-cut servo arm exit hole on the aileron servo tray / hatch. This hole will allow the servo arm to pass through when installing the aileron pushrods.



3. Place the servo into the servo tray. Center the servo within the tray and drill 1,6mm pilot holes through the block of wood for each of the four mounting screws provided with the servo.

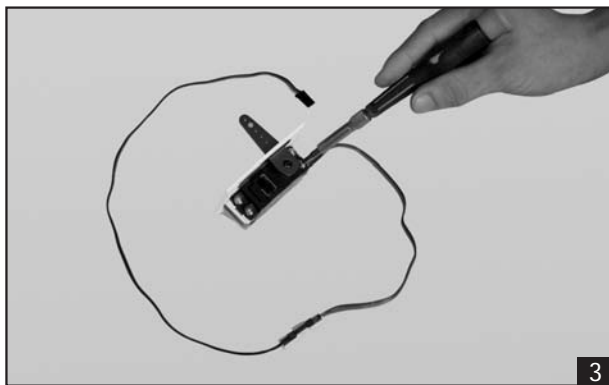

3

- Using the thread as a guide and using masking tape, tape the servo lead to the end of the thread: carefully pull the thread out. When you have pulled the servo lead out, remove the masking tape and the servo lead from the thread.

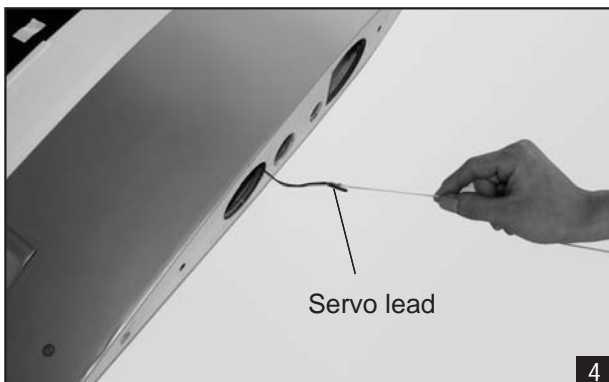

4

- Place the aileron servo tray / hatch into the servo box on the bottom of the wing and drill 1,6mm pilot holes through the tray and the servo box for each of the four mounting screws. Secure the servo tray in place using the mounting screws provided (2mm x 12mm).

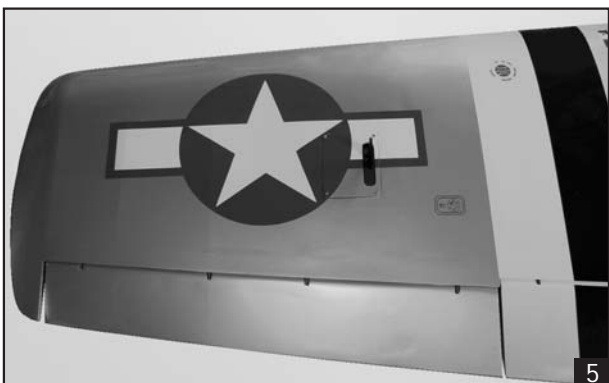

5

- Repeat step # 2 - # 5 to install the second aileron servo in the opposite wing half.

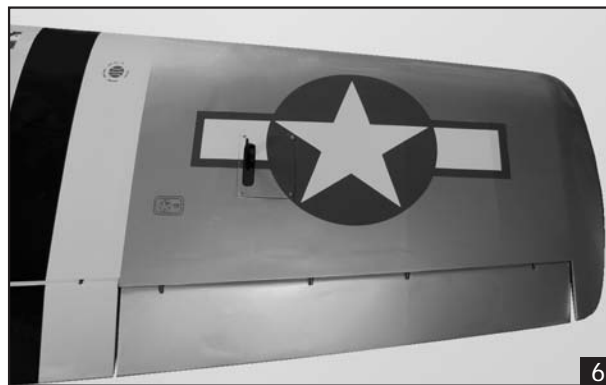

6

INSTALLING THE CONTROL HORNS

- The aileron has a block wood plate for mounting the control horn. One aileron control horn is positioned on each aileron.



7

- Screw the control horn in place.



8

- Repeat step # 1 - # 2 to install the second control horn on the aileron.



INSTALLING THE AILERON LINKAGES

1. The aileron linkages are assembled as shown below.

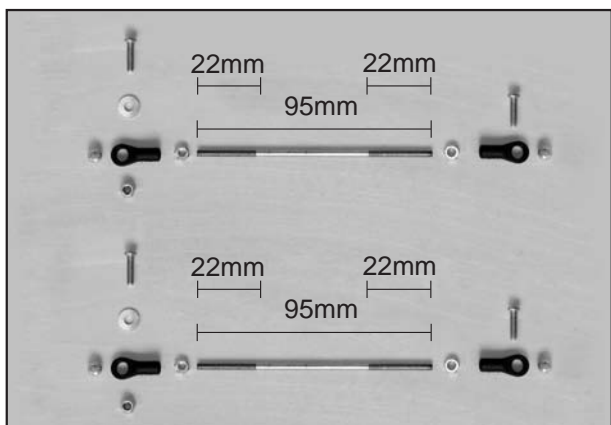

2. Install the link ball to the control horn.

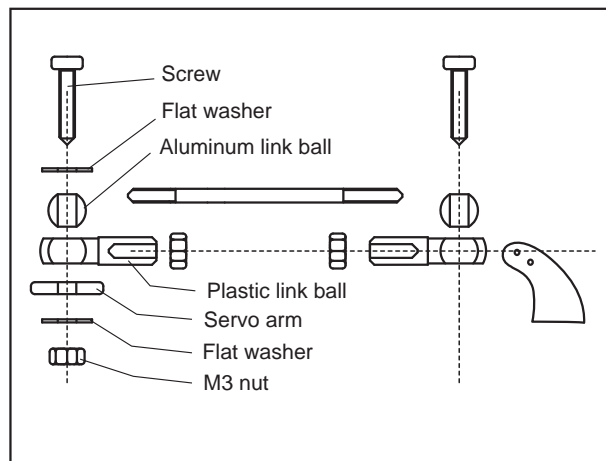
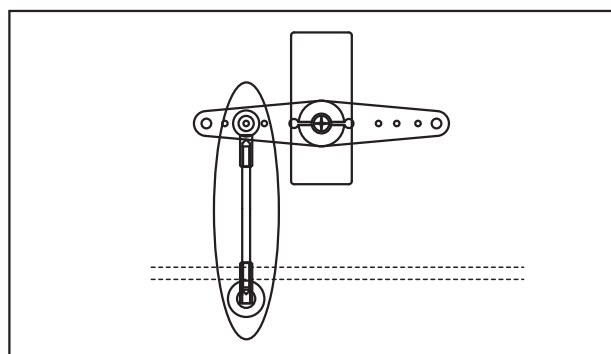

3. Repeat step 1 - step 3 for the second aileron linkage.

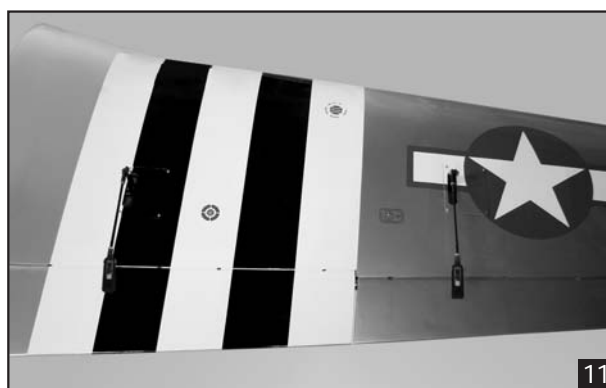

INSTALLING THE FLAP

Repeat these step from installing the aileron for installing the flap.

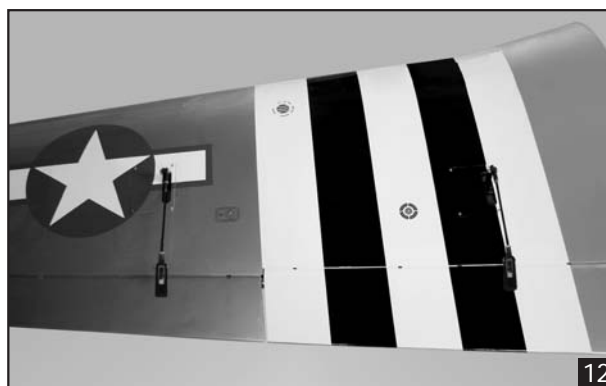

INSTALLING THE LANDING GEAR

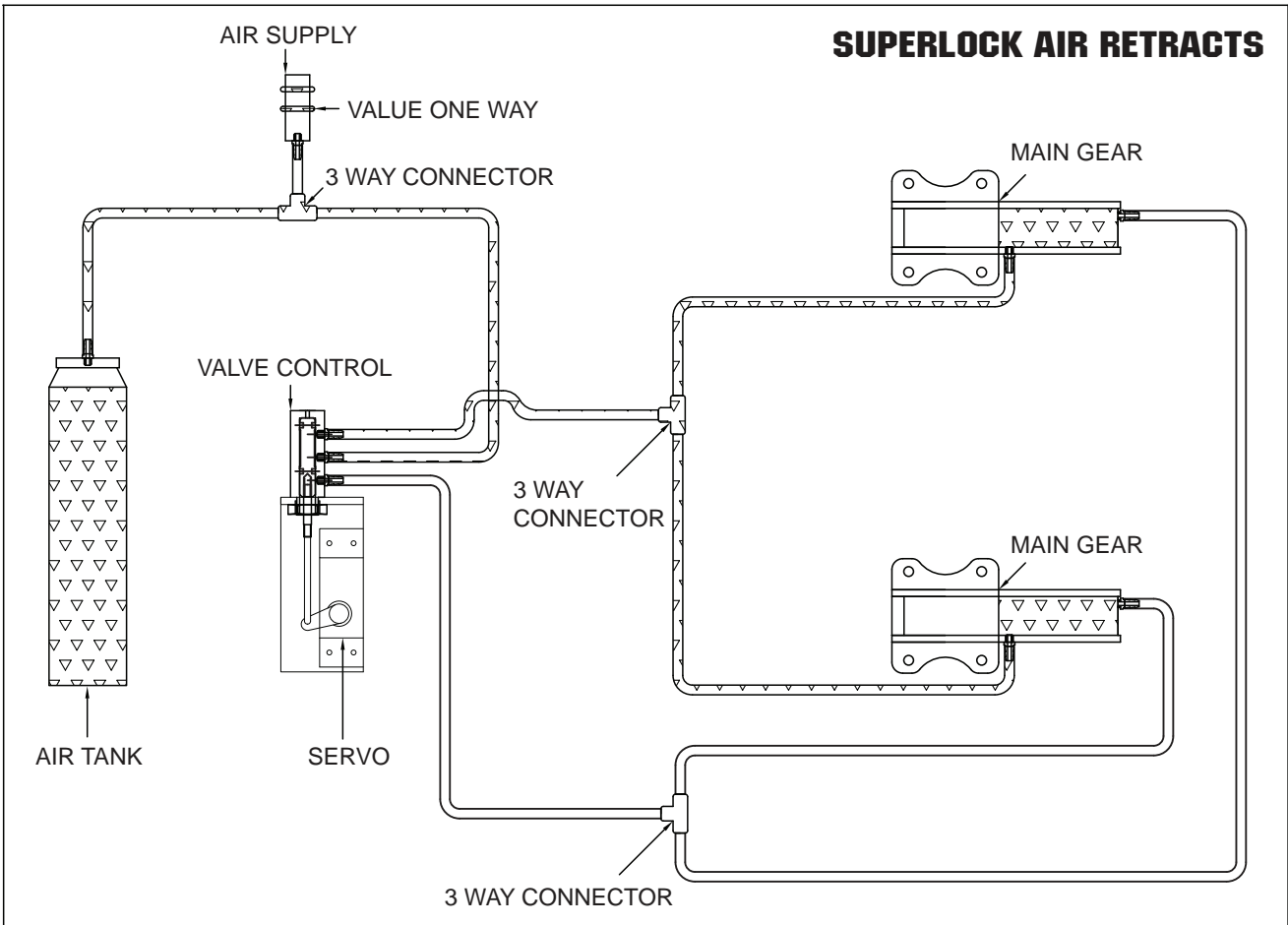

1. Install the tube to the air retract.

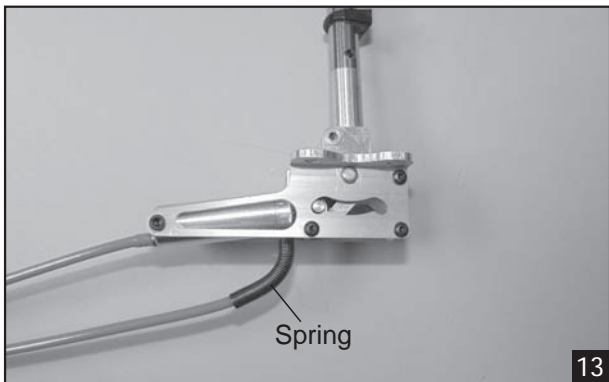

3. Secure the air retract to the wing.

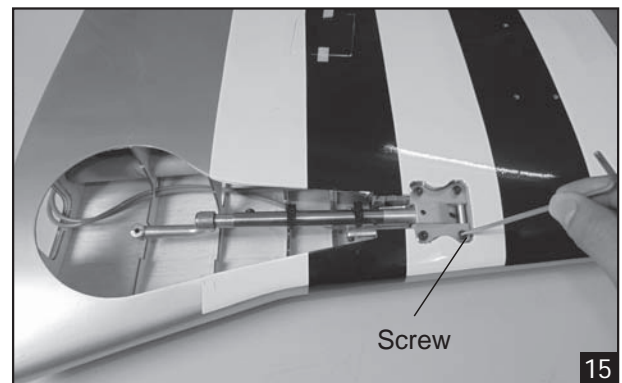

2. Place the retract to the wing and pull out the air tube through the wing section.

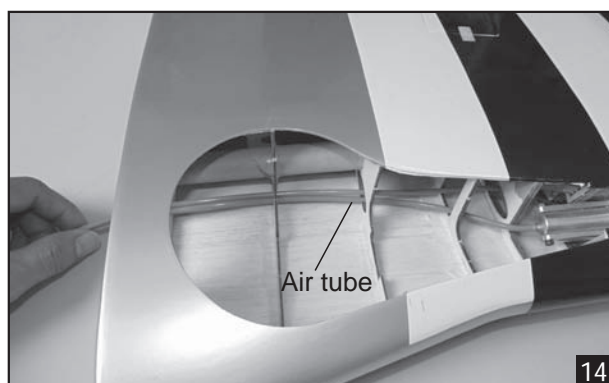

4. Trim the wheel well.



5. Glue the plastic wheel well by C.A glue.

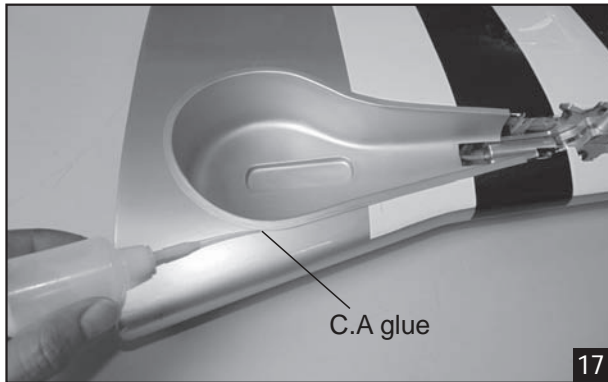

6. Secure the axle.

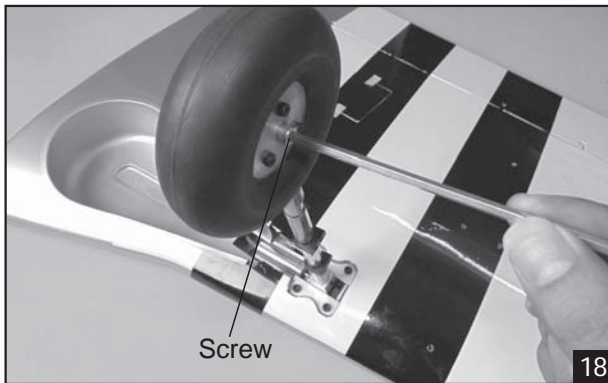

7. Secure the wheel.

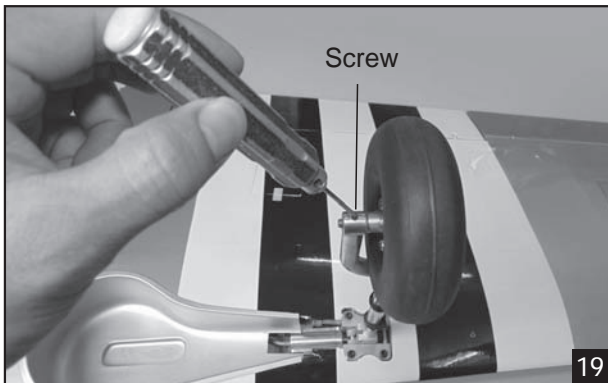

8. Secure the wheel cover.

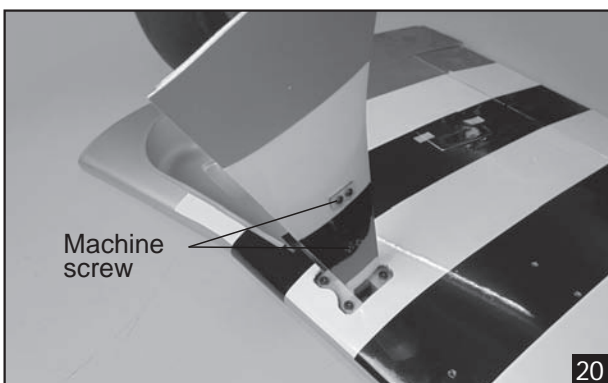

9. Make the same way for install the second landing gear.

JOINING THE FUSELAGE

- Joining the fuselage using 3 aluminum tube.

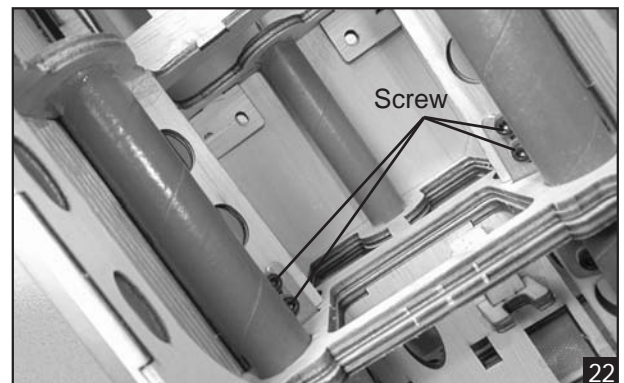
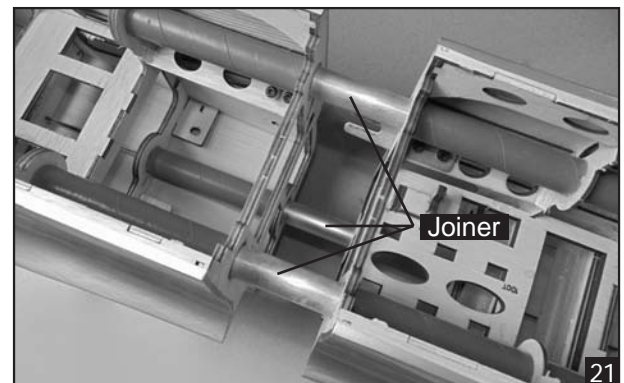

INSTALLING THE HORIZONTAL STABILIZER

1. Slide the joiner to the horizontal stabilizer.

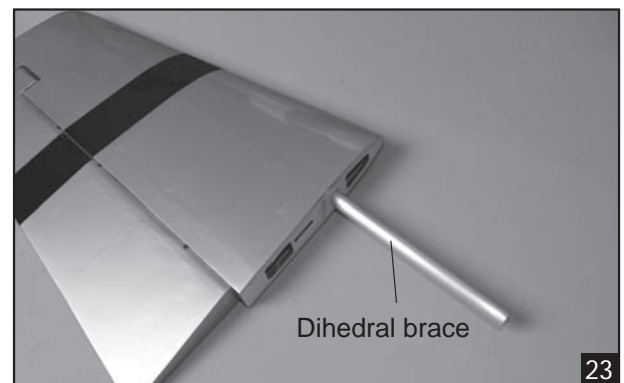

2. Attach the stabilizer to the fuselage.

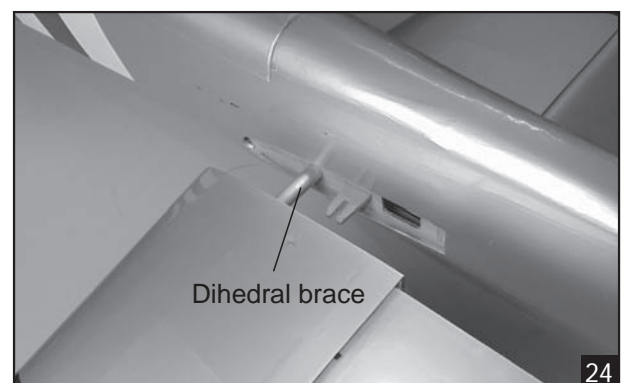

- Secure the stabilizer.



25

SERVO INSTALLATION

INSTALLING THE FUSELAGE SERVOS

- Install the rubber grommets and brass collets into the elevator, rudder and throttle servos. Test fit the servos into the servo tray. Trim the tray if necessary to fit your servos
- Mount the servos to the tray using the mounting screws provided with your radio system.

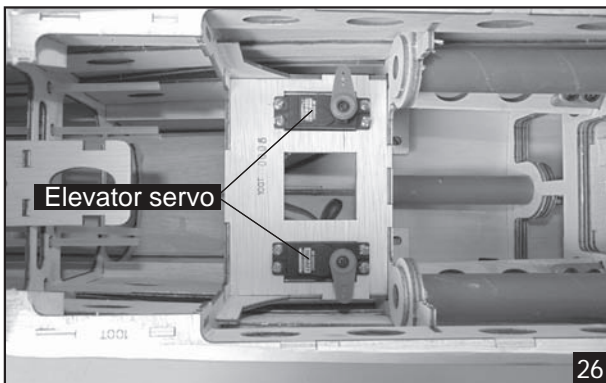

26

INSTALLING THE ELEVATOR PUSHROD

- Locate the pushrod exit slot on the right side and left side of the fuselage. It is located slightly ahead and below the horizontal stabilizer.
- Carefully cut away the covering material from the slot.

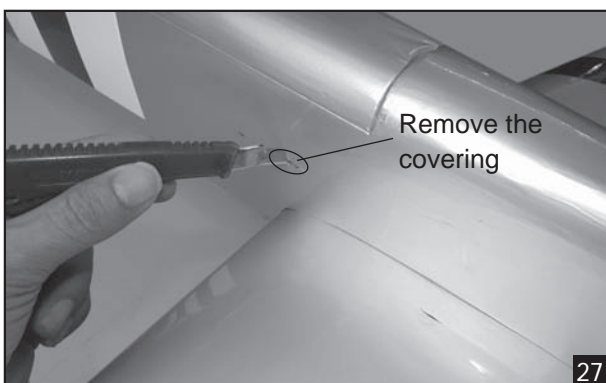

27

- Working from inside the fuselage, slide the threaded end of the pushrod until it reaches the exit slot. Carefully reach in with a small screw driver and guide the pushrod out of the exit slot.
- Install the clevis into the two elevator pushrod. Make sure 6mm of thread shows inside the clevis.



28

- The control horn should be mounted on the bottom, left side and right side of the elevator at the leading edge, in line with the elevator pushrod.
- Remove the covering from the slot and secure the control horn in place.

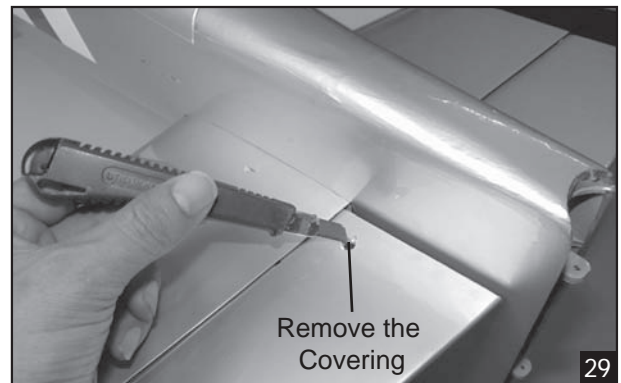

29



30

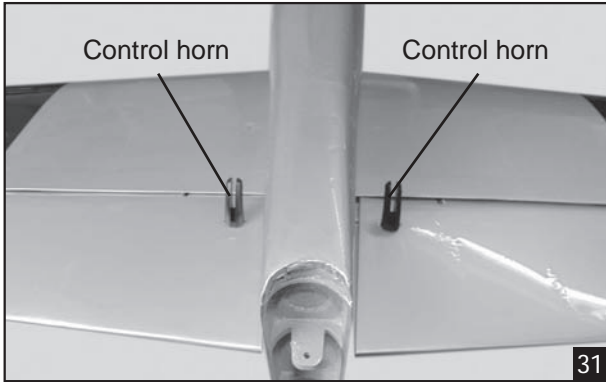

7. Secure clevis to the hole in the control horn.



8. Locate one nylon servo arm, and using wire cutters, remove all but one of the arms. Using a 2mm drill bit, enlarge the third hole out from the center to accommodate the elevator pushrod wire.
9. Plug the elevator servo into the receiver and center the servo. Install the servo arm onto the servo. The servo arm should be perpendicular to the servo and point toward the middle of the fuselage.
10. With the elevator halves and elevator servo centered, carefully place a mark on the elevator pushrod wire where it crosses the hole in the servo arm.
11. Using pliers, carefully make a 90 degree bend up at the mark made. Cut off the excess wire, leaving about 8mm beyond the bend.

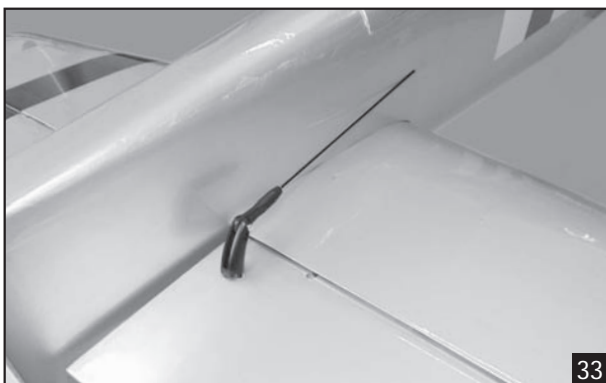

12. Make the same way for the second elevator.

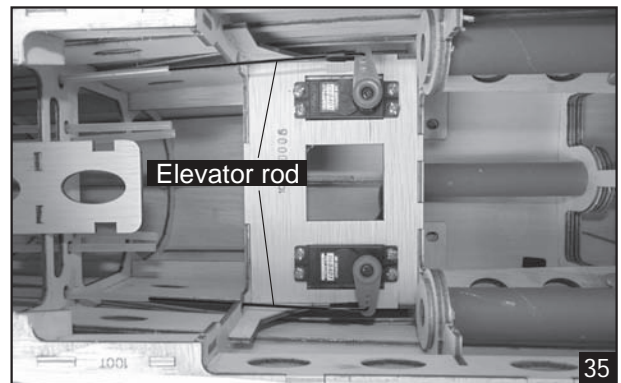
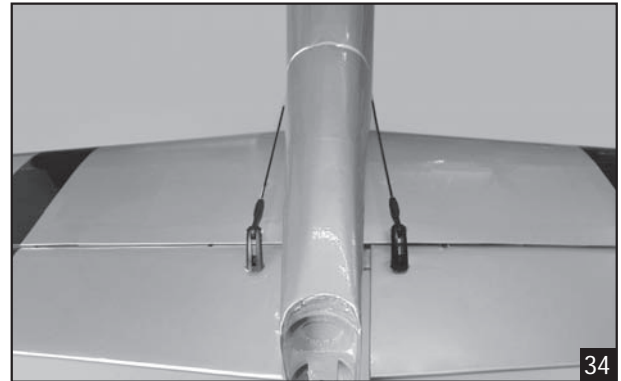

INSTALLING THE VERTICAL STABILIZER

1. Remove the covering from the Bottom of the rudder.

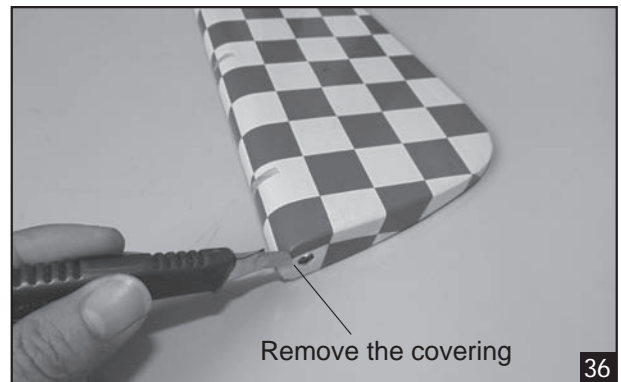

2. Slide the joiner to the rudder.

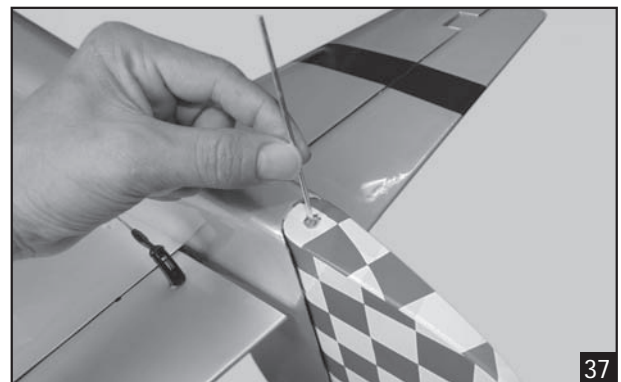

3. Glue the exit hole.

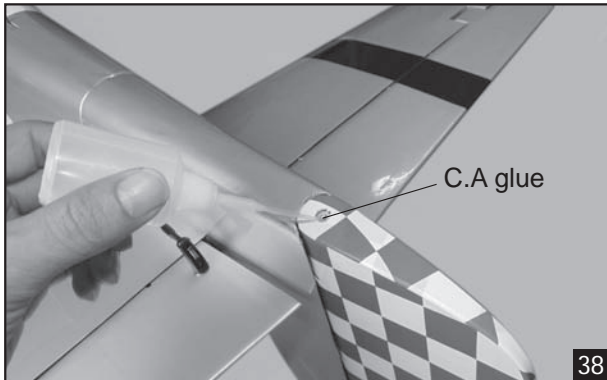

INSTALLING THE RUDDER SERVO

Install the rudder servo to the fuselage as shown.



INSTALLING THE RUDDER LINKAGES

The rudder is controlled by two metal cables. Install the rudder linkages and cables as below.

1. Use a hobby knife to remove the covering from the openings for the rudder control cables.



2. The rudder has a block wood plate for mounting the control horn. Two control horn in positioned on both side rudder (left and right).

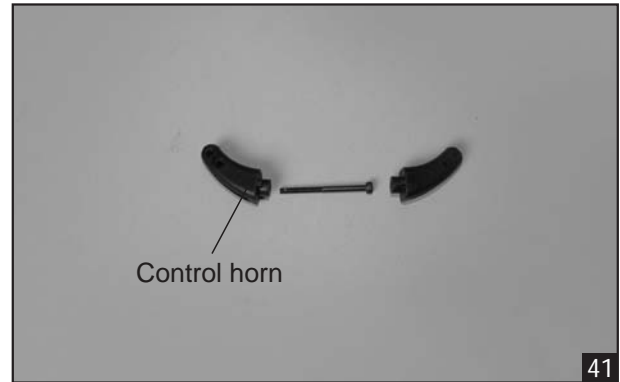

3. Install the control horn to the rudder.

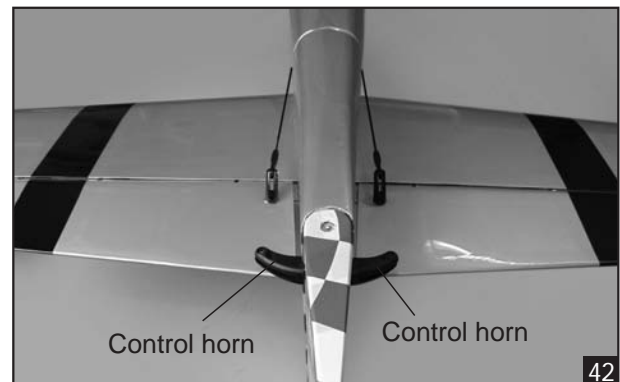

4. Slide a crimp onto the cable, then pass the cable through the threaded cable end. Pass the cable back into the crimp and use crimping pliers to secure the crimp to the cable. Guide the cable into the fuselage to the position for the rudder servo.

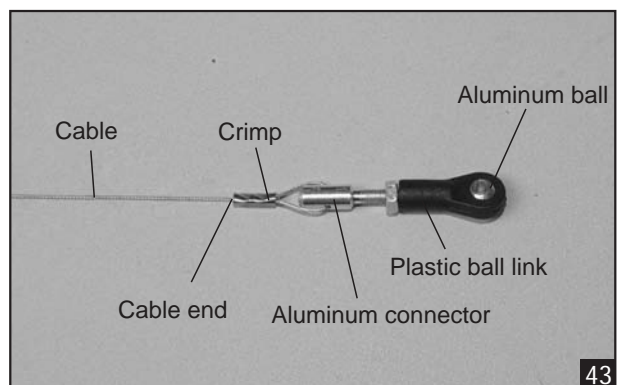

5. Thread the metal connector to the link ball.

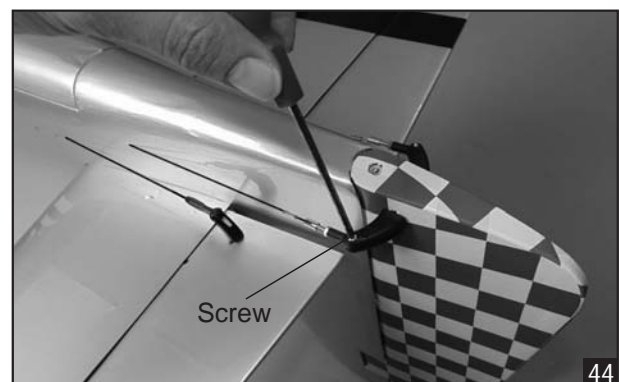



6. Center the rudder servo using the radio and install the servo arm. Attach the metal clevis to the rudder servo arm.
7. Slide a crimp onto the cable, then pass the cable through the threaded cable end. Pass the cable back into the crimp and use crimping pliers to secure the crimp to the cable.
8. Thread the metal connector to the metal clevis.
9. Attach the clevis to the rudder servo. There should be light tension on each of the wires when installed properly.

! *Note: Remember use thread locking compound to secure.*

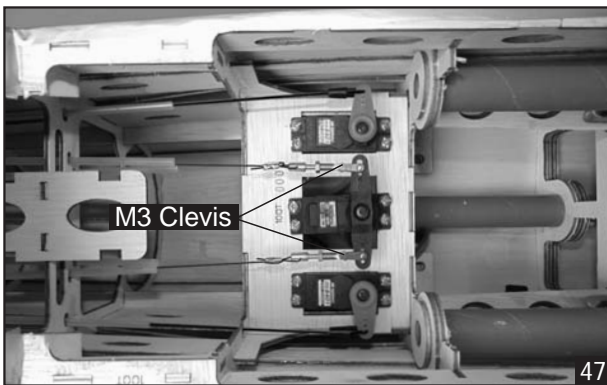
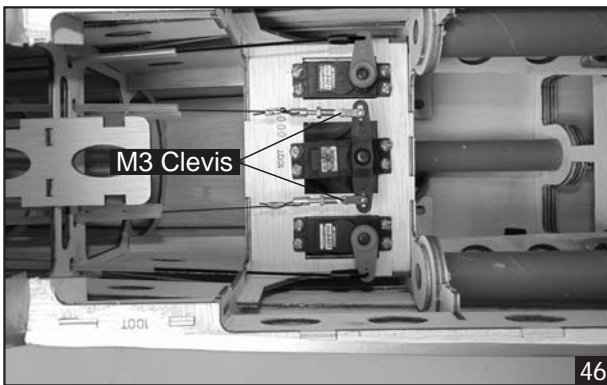

INSTALLING THE TAIL GEAR

1. The tail gear.



2. Secure the wheel.

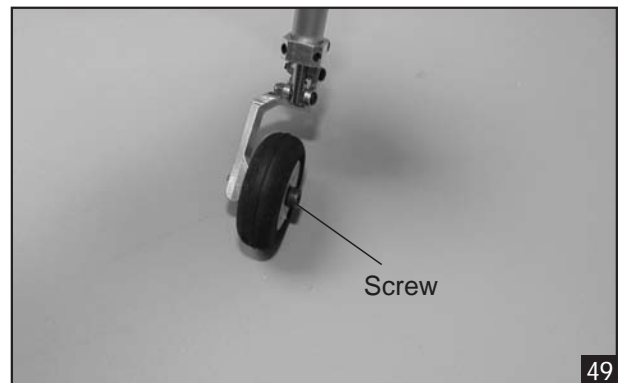

3. Secure the tail gear.

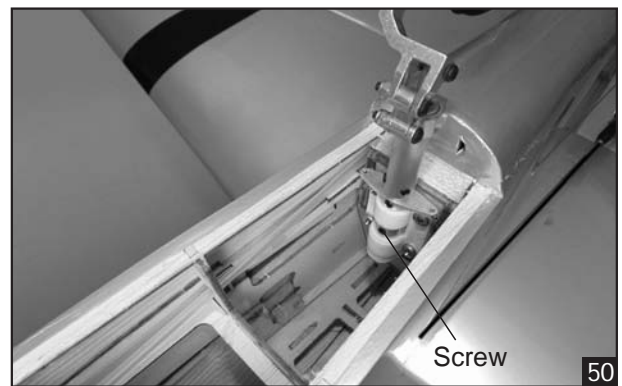

4. Slide and lock two cable to the arm of the tail gear.



5. Slide and lock two cable to the arm of the rudder servo.

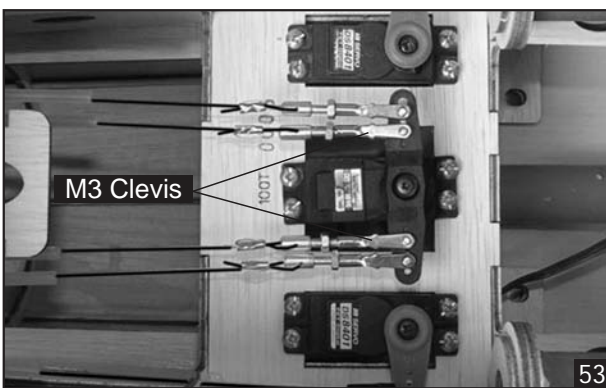
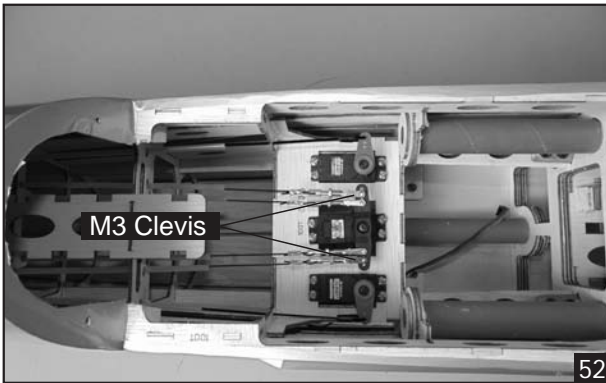

6. Open and close.

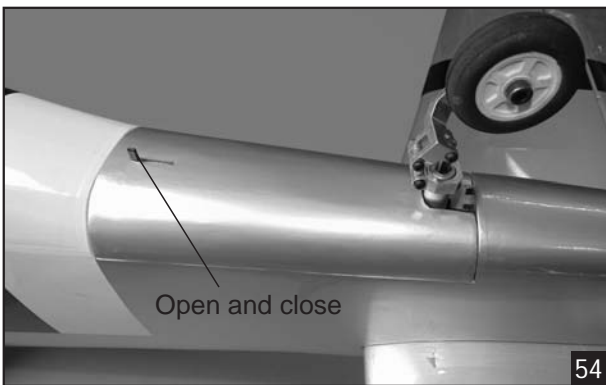

INSTALLING THE ENGINE

This manual, we used the GT 60 OS

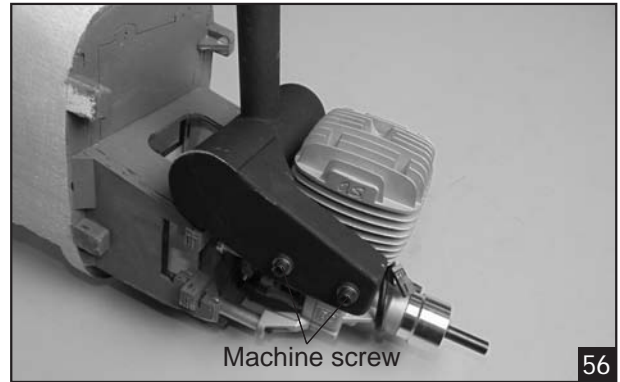
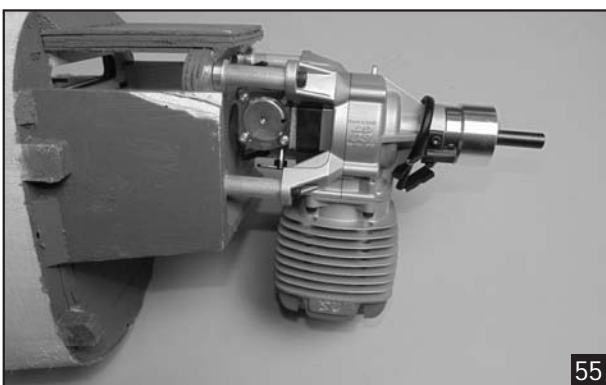

INSTALLING THE STOPPER ASSEMBLY

1. The stopper has been pre-assembled at the factory.
2. Using a modeling knife, cut one length of silicon fuel line (the length of silicon fuel line is calculated by how the weighted clunk should rest about 5mm away from the rear of the tank and move freely inside the tank). Connect one end of the line to the weighted clunk and the other end to the nylon pick up tube in the stopper.
3. Carefully bend the second nylon tube up at a 45 degree angle (using a cigarette lighter). This tube will be the vent tube to the muffler.
4. Carefully bend the third nylon tube down at a 45 degree angle (using a cigarette lighter). This tube will be vent tube to the fueling valve

! *When the stopper assembly is installed in the tank, the top of the vent tube should rest just below the top surface of the tank. It should not touch the top of the tank.*

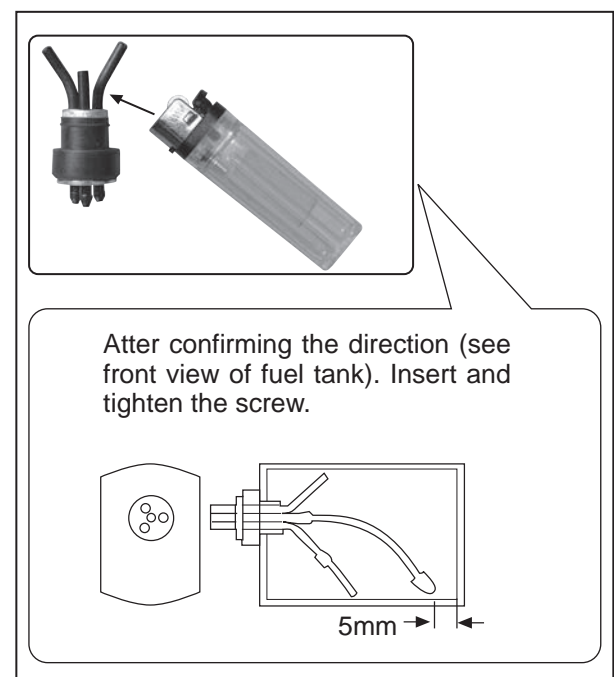

5. Test fit the stopper assembly into the tank. It may be necessary to remove some of the flashing around the tank opening using a modeling knife. If flashing is present, make sure none of it falls into the tank.
6. When satisfied with the alignment of the stopper assembly tighten the 3mm x 20mm machine screw until the rubber stopper expands and seals the tank opening. Do not over tighten the assembly as this could cause the tank to split.
7. Using a modeling knife, cut 3 lengths of fuel line 150mm long. Connect 2 lines to the 2 vent tubes and 1 line to the fuel pickup tube in the stopper.
8. Feed three lines through the fuel tank compartment and through the pre-drilled hole in the firewall. Pull the lines out from behind the engine, while guiding the fuel tank into place. Push the fuel tank as far forward as possible, the front of the tank should just about touch the back of the firewall. Blow through one of the lines to ensure the fuel lines have not become kinked inside the fuel tank compartment. Air should flow through easily.



Do not secure the tank into place permanently until after balancing the airplane. You may need to remove the tank to mount the battery in the fuel tank compartment.

9. To secure the fuel tank in place, apply a bead of silicon sealer to the forward area of the tank, where it exits the fuselage behind the engine mounting box and to the rear of the tank at the forward bulkhead.

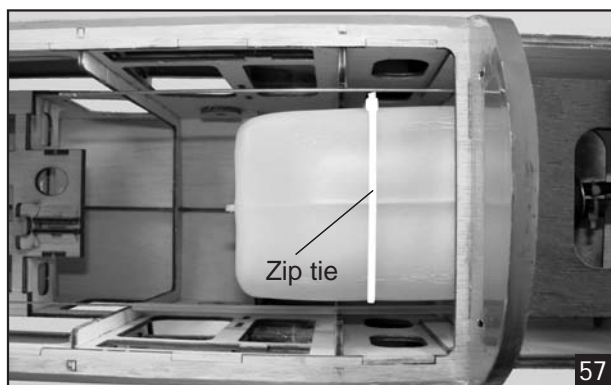

INSTALLING THE THROTTLE SERVO

1. Install the rubber grommets and brass collets into the elevator, rudder and throttle servos. Test fit the servos into the servo tray. Trim the tray if necessary to fit your servos
2. Mount the servos to the tray using the mounting screws provided with your radio system.

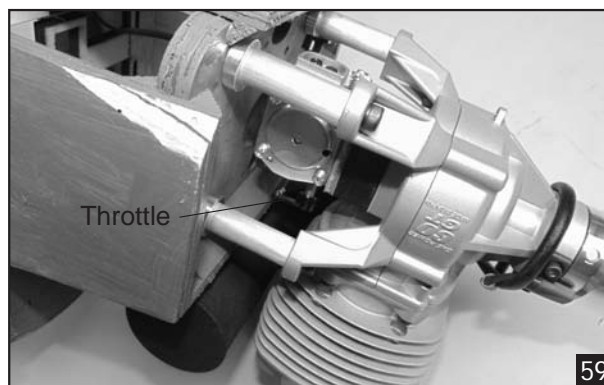
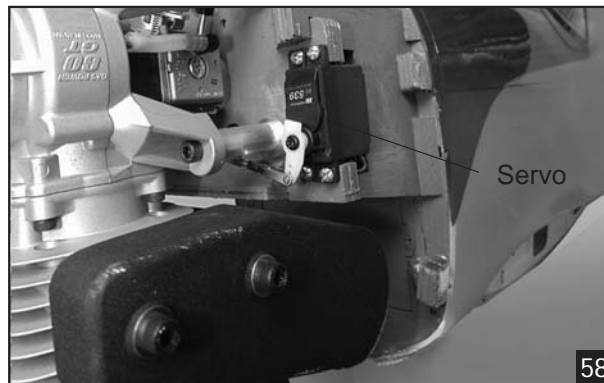

MOUNTING THE COWL

1. Measure and mark the locations to be cut out for engine head clearance, needle valve, muffler. Remove the cowl and make these cut outs using a rotary tool with a cutting disc and a rotary sanding drum attachment.
2. Slide the cowl back into place. Align the front of the cowl with the crankshaft of the engine. The front of the cowl should be positioned so the crankshaft is in the middle of the precut opening. Hold the cowl firmly in place using several pieces of masking tape.
3. While holding the cowl firmly in position, drill four 1,6mm pilot holes through both the cowl and the side edges of the firewall.
4. Using a 3mm drill bit, enlarge the four holes in the cowling.



Enlarging the holes through the cowl will prevent the fiberglass from splitting when the mounting screws are installed.

5. Slide the cowl back over the engine and secure it in place using four 3mm x 12mm wood screws.

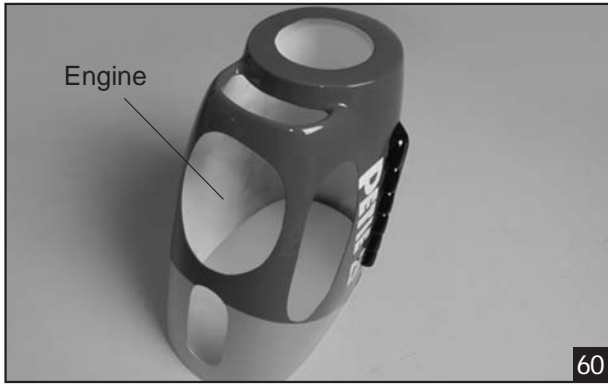

60



61



62

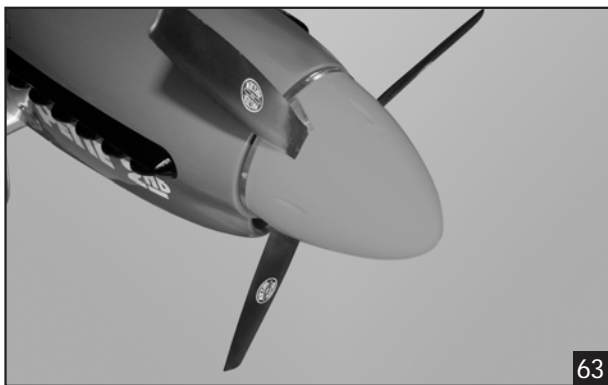

63

INSTALLING THE CONTROL AIR SYSTEM

1. Install the servo to the fuselage.

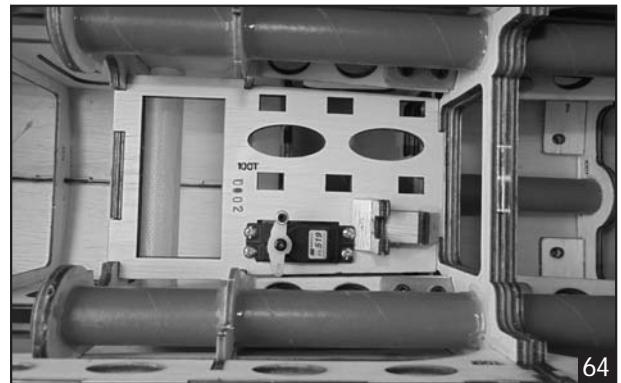

64

2. The air valve.

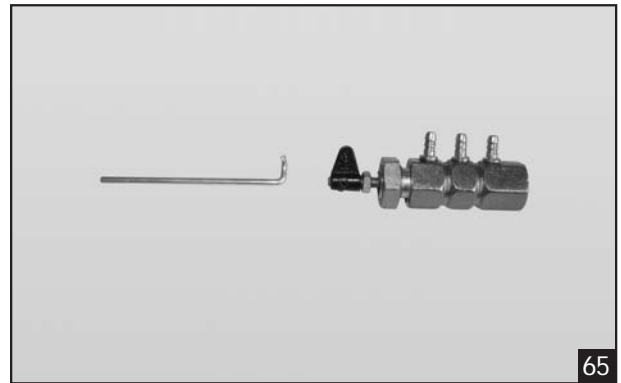

65

3. Attach the air valve to the servo.

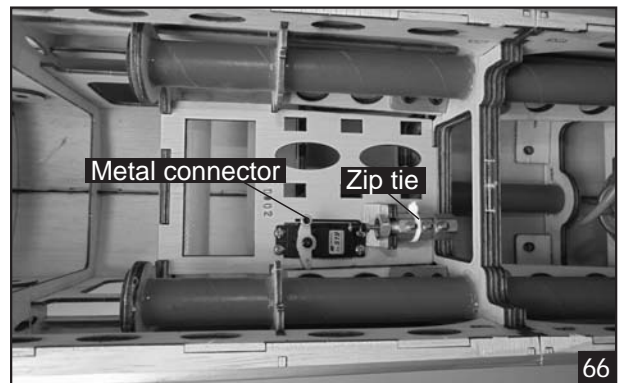

66

4. Install the air tank.

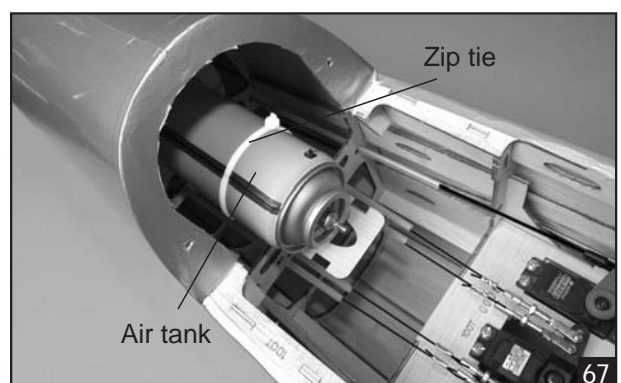

67

INSTALLING THE PLASTIC BOMB

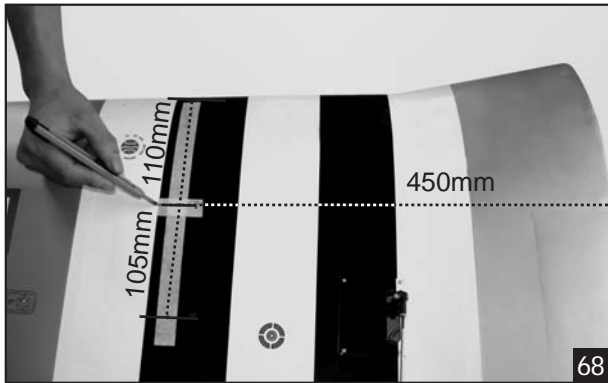

2. Glue the plastic air scoop.

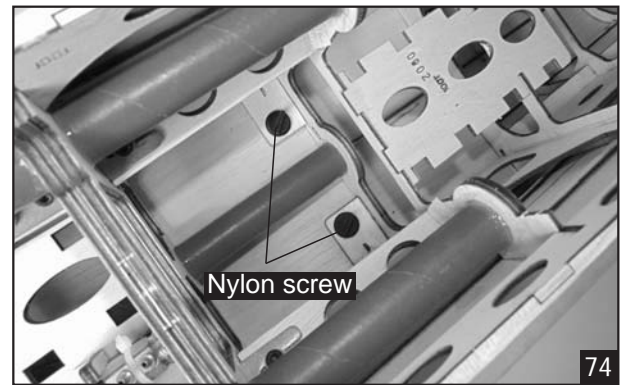
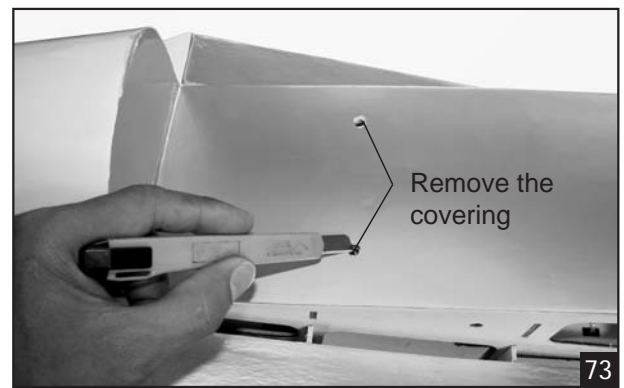
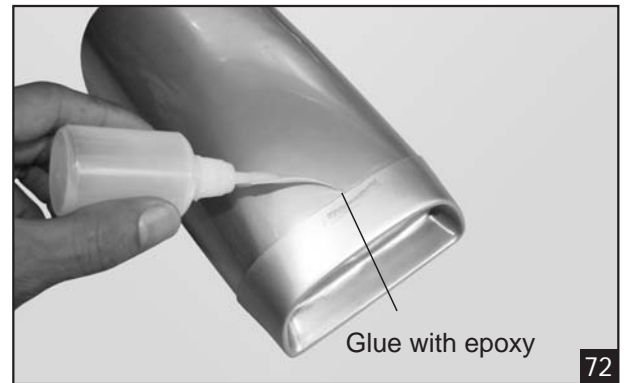

INSTALLING THE AIR SCOOP

1. Remove the covering.



BALANCING

1. It is critical that your airplane be balanced correctly. Improper balance will cause your plane to lose control and crash.

THE CENTER OF GRAVITY IS LOCATED 190mm BACK FROM THE LEADING EDGE OF THE WING, AT THE FUSELAGE.

2. Mount the wing to the fuselage. Using a couple of pieces of masking tape, place them on the top side of the wing 190mm back from the leading edge, at the fuselage sides.

3. Turn the airplane upside down. Place your fingers on the masking tape and carefully lift the plane .

4. If the nose of the plane falls, the plane is nose heavy. To correct this first move the battery pack further back in the fuselage. If this is not possible or does not correct it, stick small amounts of lead weight on the fuselage under the horizontal stabilizer. If the tail of the plane falls, the plane is tail heavy. To correct this, move the battery and receiver forward or if this is not possible, stick weight into the firewall. When balanced correctly, the airplane should sit level or slightly nose down when you lift it up with your fingers.

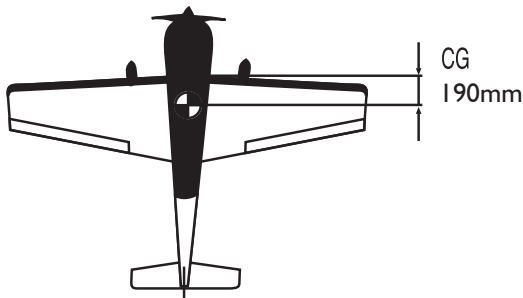

LATERAL BALANCE

 After you have balanced a plane on the C.G. You should laterally balance it. Doing this will help the airplane track straighter.

1. Turn the airplane upside down. Attach one loop of heavy string to the engine crankshaft and one to the tail wheel wire. With the wings level, carefully lift the airplane by the string. This may require two people to make it easier.
2. If one side of the wing fall, that side is heavier than the opposite. Add small amounts of lead weight to the bottom side of the lighter wing half's wing tip. Follow this procedure until the wing stays level when you lift the airplane.

CONTROL THROWS

1. We highly recommend setting up a plane using the control throws listed.
2. The control throws should be measured at the widest point of each control surface.
3. Check to be sure the control surfaces move in the correct directions.

Low rate:

Aileron	15mm up	15mm down
Elevator	15mm up	15mm down
Rudder	40mm right	40mm left
Flap	25-35mm down	

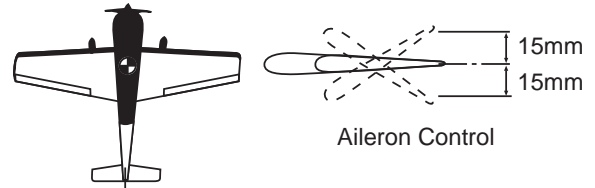

Aileron Control



Elevator Control



Rudder Control



Flap Control

FLIGHT PREPARATION PRE FLIGHT CHECK

1. Completely charge your transmitter and receiver batteries before your first day of flying.
2. Check every bolt and every glue joint in your plane to ensure that everything is tight and well bonded.
3. Double check the balance of the airplane
4. Check the control surface
5. Check the receiver antenna . It should be fully extended and not coiled up inside the fuselage.
6. Properly balance the propeller.

I/C FLIGHT GUIDELINES

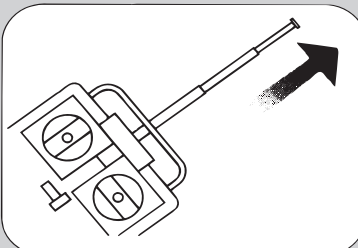

When ready to fly, first extend the transmitter aerial.

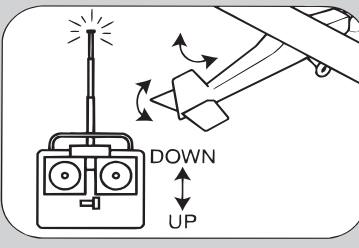

Operate the control sticks on the transmitter and check that the control surfaces move freely and in the **CORRECT** directions.

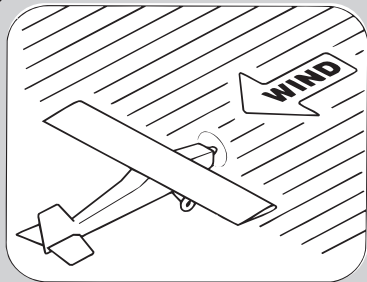

ALWAYS land the model **INTO** the wind, this ensures that the model lands at the slowest possible speed.

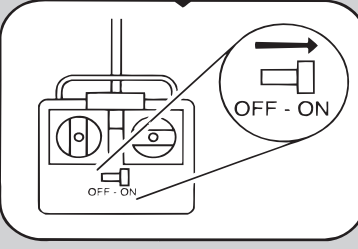

Switch on the transmitter.

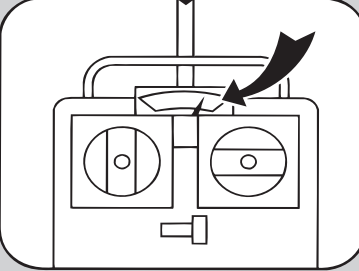

Check that the transmitter batteries have adequate power.

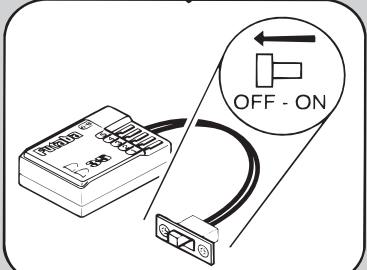

Switch off the receiver.

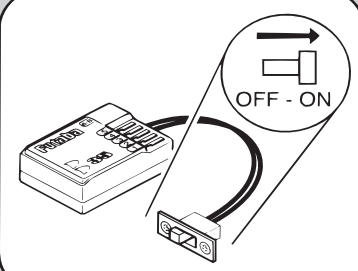

Switch on the receiver.



ALWAYS take off into the wind.

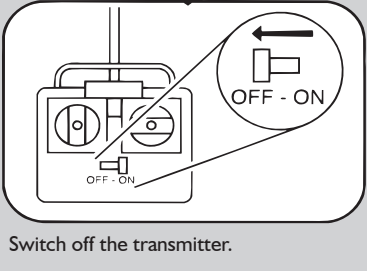

Switch off the transmitter.

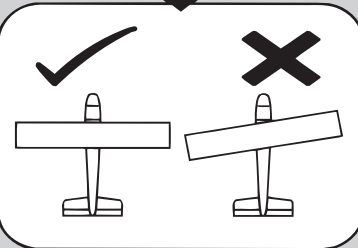

Check that the wings are correctly fitted to the fuselage.

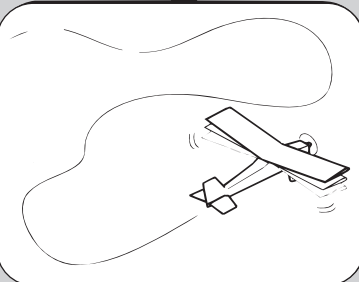

If the model does not respond correctly to the controls, land it as soon as possible and correct the fault.

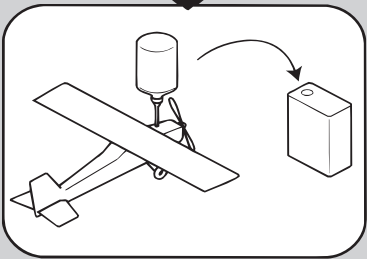

Empty the fuel tank after flying, fuel left in the tank can cause corrosion and lead to engine problems.