

SUPER-E is a new brand from Techone Hobby. It focus on the design and manufacture of electrical molded models. Innovation and concentration is our principle. SUPER-E will develop more electrical molded models to you all and give you brand-new flying experience.

**Features:**

It's like a gust of wind

----- a scream

----- a beeline

----- an enjoyment

- 1.Wing fences on the leading edge make the flying more stable.
- 2.Upper dihedral angle design increases the stability of flying wing's landscape orientation.
- 3.Proper size double rudders strengthen the plane's maneuverability and stability.
- 4.Easy to install and knock-down ducted fan used. Thrust to weight ratio is 1:1, can make vertical turn and climbing.
- 5.Use maganets to fix the equipment cabin, no need additional assembly tools.
- 6.Special servo control horn protectors are applied, they also can be used as skip.

**Product Specifications**

Fuselage length: 630mm ( 24.8 in.)

Wingspan: 1230mm ( 48.4 in.)

Flying Weight: 660-710g ( with battery )

Power: 64mm edf

Motor: 2010 KV 5000 Brushless Outrunner (installed)

ESC: 40 Amp

Servo: 9g\*2 micro servo

Radio:4/more channel

Receiver:4/more channel

Battery: 11.1V 1800-2500mah lipo 25c

Recommended Environment: Outdoor

Assembly Time: Less than 1 Hour

**Examine your kit carefully!**

Super-e model kits are subject to constant quality checks throughout the production process, and we sincerely hope that you are completely satisfied with the contents of your kit. However, we would ask you to check all the parts before you start construction, referring to the Parts List, as we cannot exchange components which you have already modified. If you find any part is not acceptable for any reason, we will readily correct or exchange it once we have examined the faulty component. Just send the offending part to our Model Department. Please be sure to include the enclosed complaint form, duly completed. We are constantly working on improving our models, and for this reason we must reserve the right to change the kit contents in terms of shape or dimensions of parts, technology, materials and fittings, without prior notification. Please understand that we cannot entertain claims against us if the kit contents do not agree in every respect with the instructions and the illustrations.

**Caution!**

Radio-controlled models, and especially model aircraft, are by no means playthings in the usual sense of the term. Building and operating them safely requires a certain level of technical competence and manual skill, together with discipline and a responsible attitude at the flying field. Errors and carelessness in building and flying the model can result in serious personal injury and damage to property. Since we, as manufacturers, have no control over the construction, maintenance and operation of our products, we are obliged to take this opportunity to point out these hazards and to emphasise your personal responsibility.

**Do not fly under the conditions below**

Wind strong enough to make the trees rustle.

A street with many trees or street lamps.

Close to high voltage electrical wires.

High Population density areas.

**Cautions for flying**

Front lawns and parks make excellent flying areas. Make sure you have permission to fly and follow safety guidelines set by local authorities. The calmer the wind, the better!

**Note for Storage**

Please disconnect the lipo packs when finished flying.

Do not press or crush the airplane when storing.

The best way to store is to hang the airplane to keep the control surface rigid.

**Tools:**

Scissors, balsa knife, combination pliers, screwdriver. quick-dry glue

**Applying the decals**

Please note we applied all the labels in our factory. In case that some orders are not required to apply labels, please apply the label by yourself according to above pictures.

**Foam parts included in the packing:**

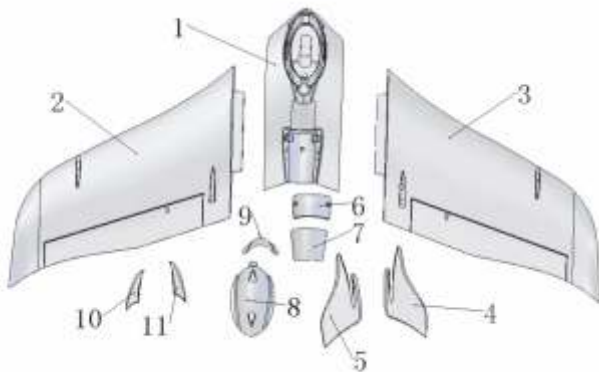

- 1. Fuselage
- 2. Left wing
- 3. Right wing
- 4. Right Rudder
- 5. Left Rudder
- 6. EDF cabin
- 7. Air outlet
- 8. Equipment cabin canopy
- 9. Nose cover
- 10. Left wing fence
- 11. Right wing fence

**Parts included in the packing**

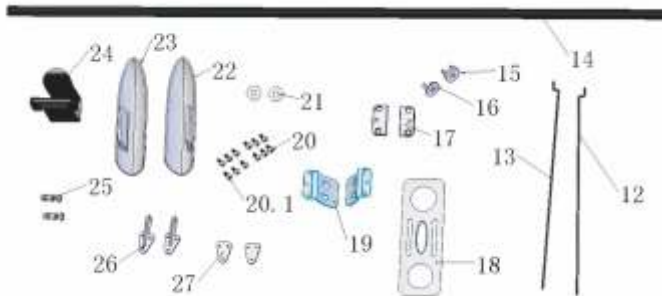

- 12. Right push rod 1.2\*135MM
- 13. Left push rod 1.2\*135MM
- 14. Wings connecting carbon tube 6\*4\*408mm
- 15. Magnet D10MM
- 16. Iron slice D10mm
- 17. EDF fixing reinforcements 2pcs
- 18. Battery fixing board
- 19. EDF fixing frame 2pcs
- 20. EDF fixing screws D2.3\*14mm 6pcs (4pcs for EDF fixing, 2pcs for fixing EDF cabin )
- 20.1 Control horn fixing screws D2\*15mm 6pcs
- 21. EDF cabin fixing reinforcements 2pcs
- 22. Right servo arm protector
- 23. Left servo arm protector
- 24. Battery velcro band
- 25. Pushrod adjustor
- 26. Control horn 2pcs
- 27. Control horn reinforcements 2pcs

**ASSEMBLY STEPS**

**NOTE: We finished most of following steps in our factory, they're listed for your reference only.**

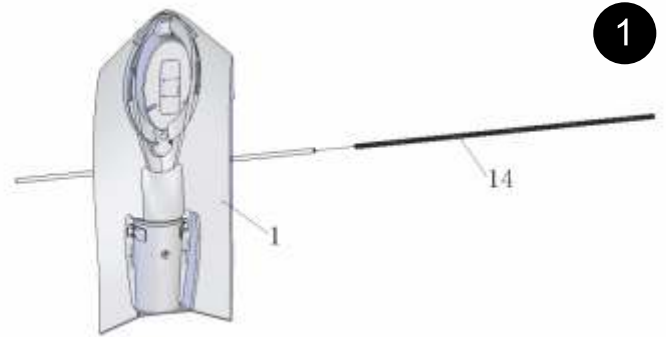

Insert wings connecting carbon tube into fuselage, make sure the length of both left and right side are the same.

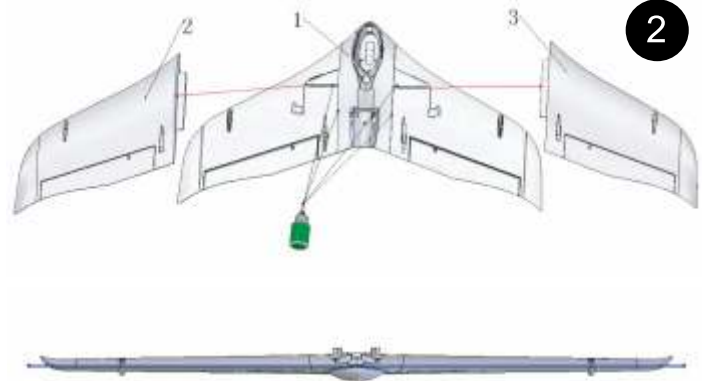

Insert left and right carbon tube of fuselage into corresponding hole of left and right wing. Then drop some glue on the joints of wings and fuselage to fix. Note: Make sure the two wings are flat and on the same beeline, no distortion before fix.

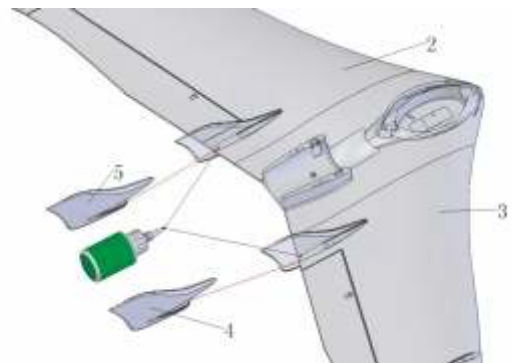

Insert double rudders into corresponding slots on wings, then use glue to fix. Note: Make sure the two rudders are perpendicular to the wing surface.

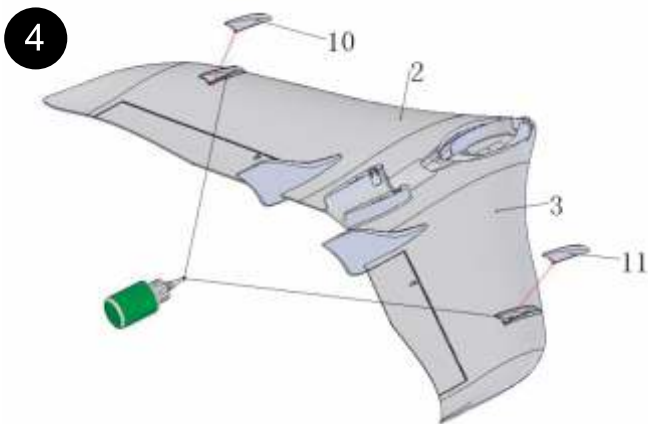

4  
Glue the two wing fences on corresponding slots of both wings.

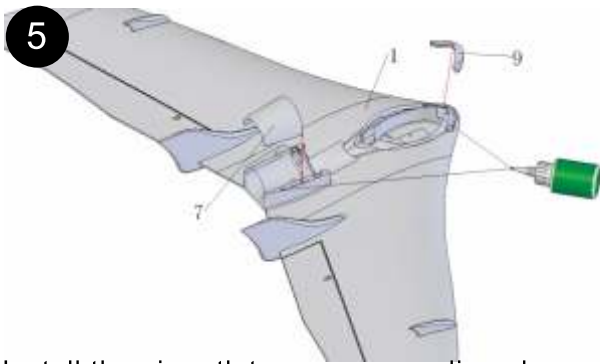

5  
Install the air outlet on corresponding place of fuselage with glue. And install the nose cover on the nose with glue.

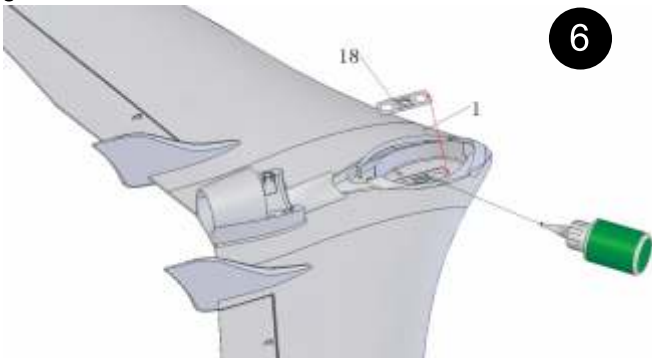

6  
Glue the battery fixing board into the equipment cabin. Make sure it's glued and fixed firmly.

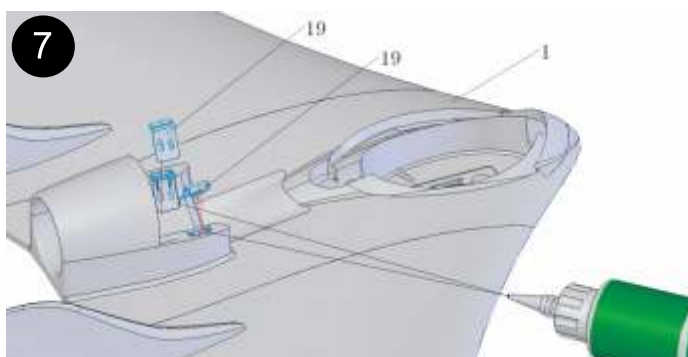

7  
Glue 2pcs EDF fixing frames onto corresponding places on the left and right EDF cabin.

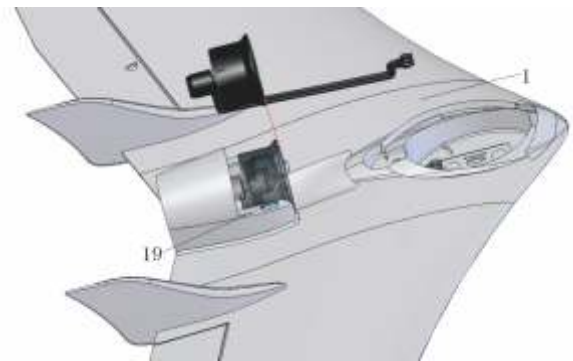

8  
Install the EDF with motor: pass the 3 motor wires through the hole on the fuselage, then through the hole on the bottom equipment cabin, finally into equipment cabin.

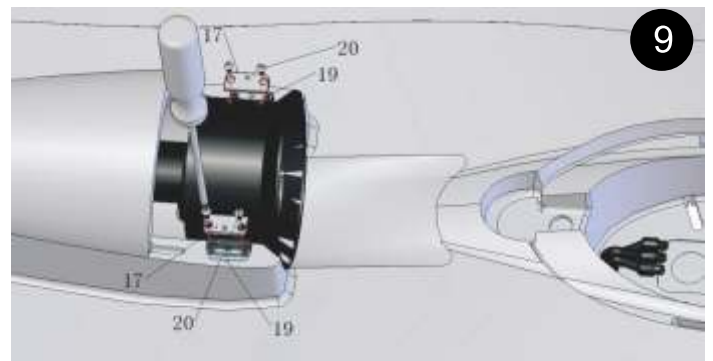

9  
Press the EDF fixing reinforcements on the sides of EDF, then use 4pcs EDF fixing screws to fix. Make sure the EDF is fixed firmly.

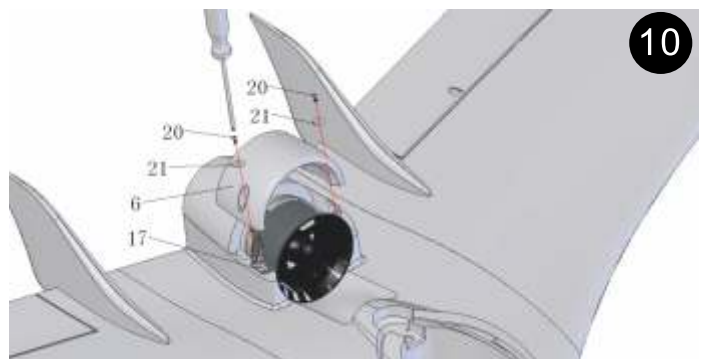

10  
Put the EDF cabin on the EDF and EDF cabin fixing reinforcements in the holes of cabin, then use 2pcs EDF fixing screws to fix.

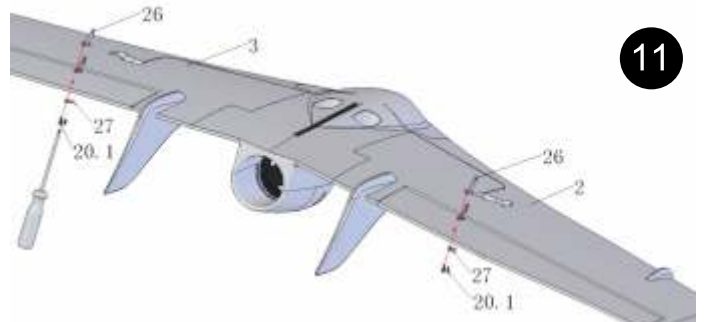

11  
Use control horn fixing screws to install left and right control horns.



After installed the servo arms, then glue the servos into corresponding slots on bottom wings.

**Note:**

1. Make sure the servo arm is centered.
2. Please use servo extension once the servo wire is limited.

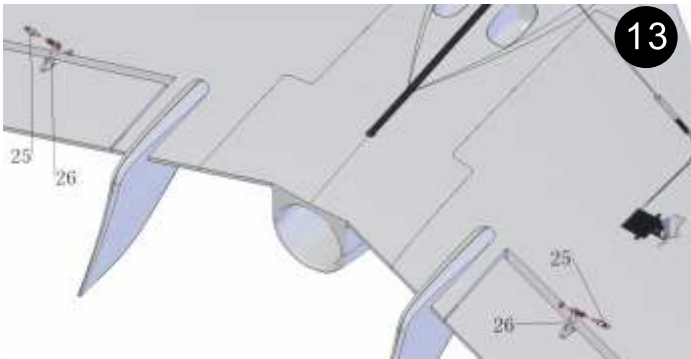

Install the pushrod adjustor.

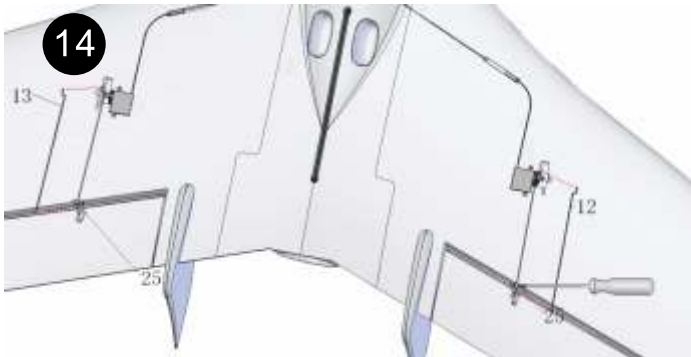

Install left and right push rods, firstly install the side of servo arms, then install the side of push rod adjustor. Note: Make sure the control surfaces is neutral before screw down the push rod adjustor.

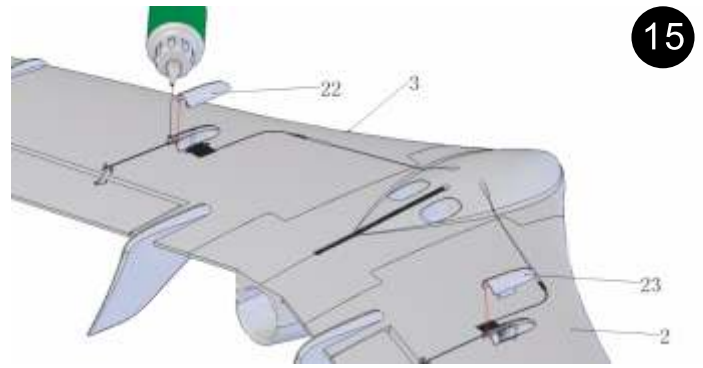

Install the servo arm protectors onto corresponding places of both wings. They're used to protect servo arms and also as a skid.

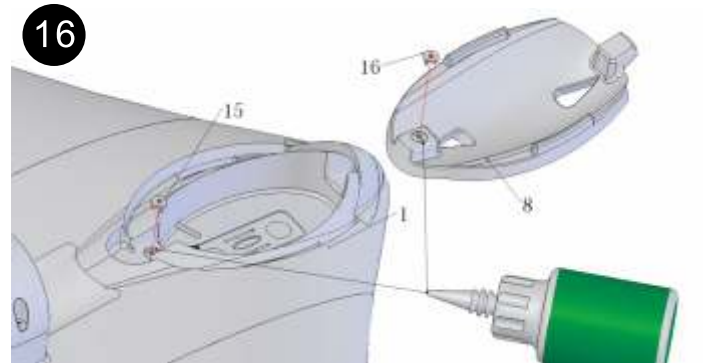

Glue the magnet and iron slice onto corresponding places as picture shown.

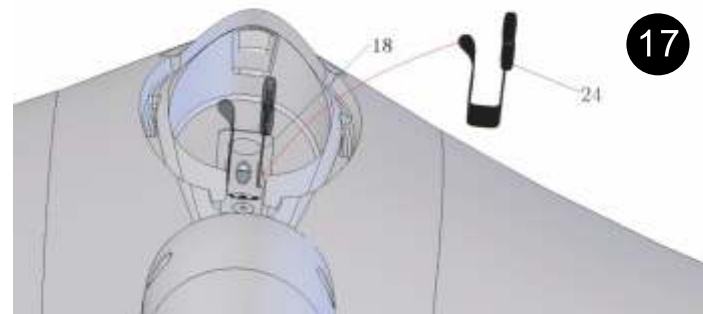

Pass battery velcro band through the two slots on battery fixing board.



Install receiver, ESC and battery, and power on, then debug before fly.

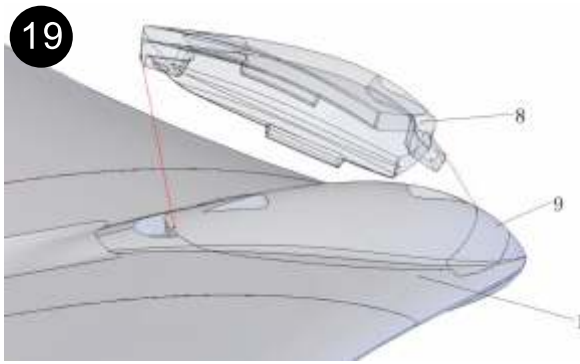

After test, you can cover the equipment cabin canopy as picture shown.

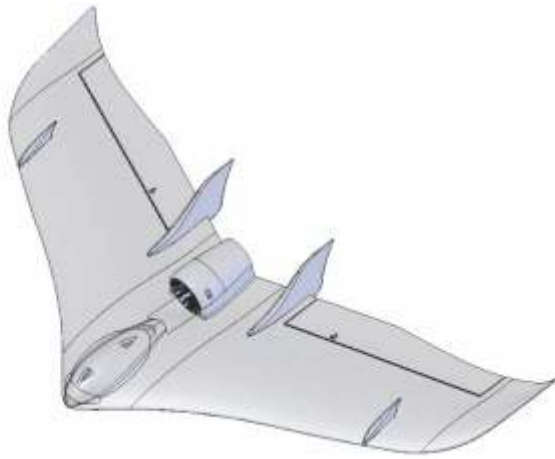

### Recommended Flying Setup

Max servo travel of aileron: 25 degrees up and 25degrees down (30mm)

Max servo travel of elevator:25 degrees up and 25 degrees down (30mm)

Setting the correct control surface travels is important if you wish the model to respond to the control commands in a balanced manner.

The travels should always be measured at the widest part of the control surface.

The control surface throws are not critical, and if you are unable to set the exact stated travels using your transmitter's adjustment facilities, that's no problem. If the discrepancy is relatively great, you will need to re-connect the linkage using a different hole at the horn or servo output arm.

If you intend to fly the model as a trainer, we recommend that you reduce the control surface travels to about 50 - 60% of the stated values.



### Setting the Centre of Gravity

Like any other aircraft, the Neptune must be balanced at a particular point in order to achieve stable flying characteristics. Assemble your model ready to fly, and install the flight battery.

The Centre of Gravity (CG) should be at a position of 170-180 mm away from root leading edge, please refer to above picture.

Support the model at this position on two fingertips, and it should balance level. If not, you can move the flight battery forward or aft to correct the balance point. Once the correct position is found, mark the location of the flight pack inside the model to ensure that it is always replaced in the same position.

### Preparations for the first flight

Please wait for a day with as little breeze as possible for the model's initial test-flight. The evening hours are often ideal for calm conditions.

Be sure to carry out a range check before the first flight, using the procedure described in your RC system instructions. If you encounter a problem, please don't risk a flight.

The first flight ...

If you are a beginner to model flying we strongly recommend

that you ask an experienced model pilot to help you for the first few flights.

## Hand-launching

Please don't try unpowered test-glides with this model – the result is invariably a damaged airframe. The Neptune should be hand-launched with the motor running at half-throttle, and always pointing directly into wind.

Ask an experienced modeller to hand-launch your aircraft for you.

The launcher should run forward for two or three paces, then give the machine a powerful straight launch, with the wings and fuselage level. Use the controls to hold the model in a steady, gentle climb - remember to keep the rate of ascent shallow and the airspeed high!

Allow the aeroplane to climb to a safe height, then adjust the trims on the transmitter until it flies in a perfectly straight line "hands off". While the model is still at a safe altitude, throttle back and try out the controls on the glide. Carry out a "dry run" landing approach at a safe height so that you are prepared for the real landing when the battery runs flat.

Don't try any tight turns at first, and especially not on the landing approach at low altitude. It is always better to land safely at some distance from you, than to force the model back to your feet and risk a heavy landing.

## Safety

Safety is the First Commandment when flying any model aircraft.

Third party insurance should be considered a basic essential. If you join a model club suitable cover will usually be available through the organisation. It is your personal responsibility to ensure that your insurance is adequate. Make it your job to keep your models and your radio control system in perfect order at all times. Check the correct charging procedure for the batteries you are using. Make use of all sensible safety systems and precautions which are advised for your system. An excellent source of practical accessories is the SUPER-E main catalogue, as our products are designed and manufactured exclusively by practising modellers for other practising modellers.

Always fly with a responsible attitude. You may think that flying low over other people's heads is proof of your piloting skill; others know better. The real expert does not need to prove himself in such childish ways. Let other pilots know that this is what you think too.

Always fly in such a way that you do not endanger yourself or others. Bear in mind that even the best RC system in the world is subject to outside interference. No matter how many years of accident-free flying you have under your belt, you have no idea what will happen in the next minute.

The SUPER-E team - hope you have many hours of pleasure building and flying your new model.

www.super-emodel.com  
www.techonehobby.com

Email:  
salestechone@gmail.com  
hobbytechone@gmail.com

Neptune Red: 08200R

Neptune Blue: 08200B

Item.No: 08201

Left and right wing

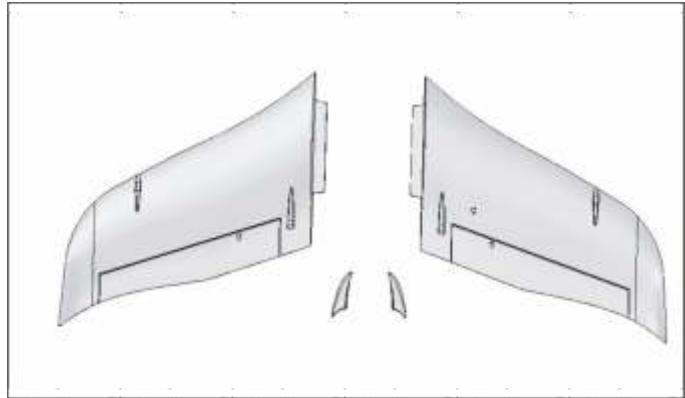

Item.No: 08202

Middle fuselage



Item.No: 08203

Double rudders





**Item.No: 08204**

**Equipment cabin canopy**



**Item.No: 08205**

**Plastic parts**



**Item.No: 08206**

**Self-adhesive color labels**



**Item.No: 08207**

**Motor+edf**



**Item.No: 08208**

**9G Servo**

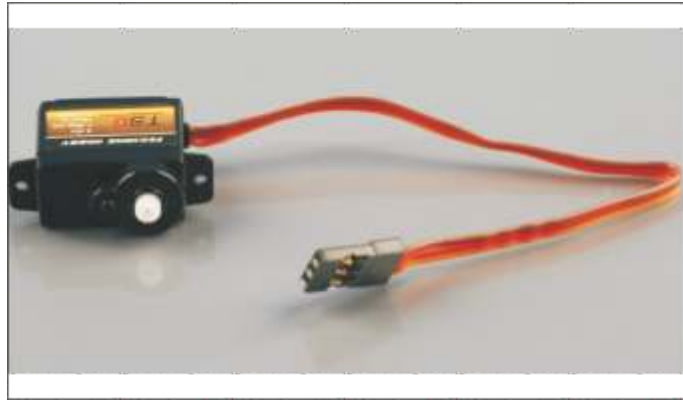

**Item.No: 08209**

**11.1v 2000mah lipo 25c battery**



**Item.No: 08210**

**40A Esc**



**Item.No: 08211**

**EDF (blades and house)**

