

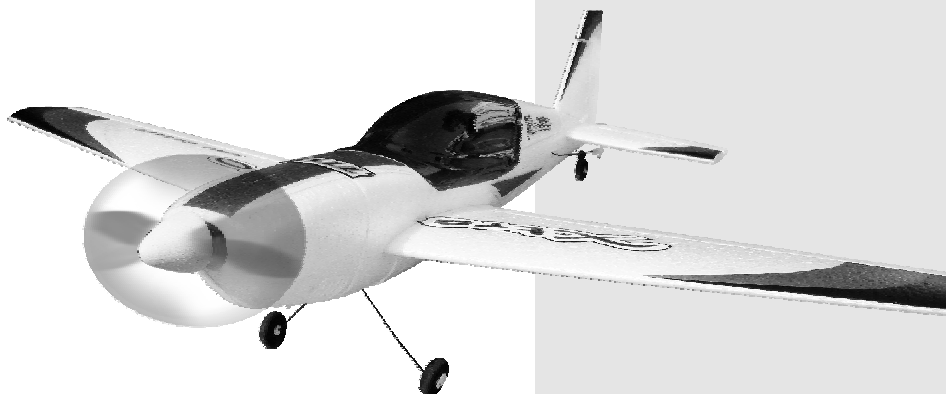

Nine Eagles™

Xtra 300

NE R/C 771B Xtra 300 Four channel
Instruction Manual



NOTHING FLIES LIKE NINE EAGLES

■ 771B1223

User Handbook

Congratulations on becoming a Nine Eagles™ airplane pilot!

To ensure safe use, please read this manual thoroughly before flying the Airplane. If you have never flown an RC Airplane before, The Xtra 300 your best choice!

	<i>Catalogue</i>	
Introduction.....		2
FCC INFORMATIONAND WARNING.....		2
Product Warning		3
LiPo Battery Safety Guidelines and warning		3
Instructions for Disposal of WEEE by Users in the European Union		6
Specification.....		6
Product List		7
Instruction for assembling the airplane		8
Battery Mounting, Charging and Maintenance		9
Transmitter Control Identification		9
Preparation before fly		12
Flying field		16
Fly practice		16
Notify Items		17
Miscellaneous		17

Introduction

Nine Eagles product NE R/C 771B Xtra 300 Four channels airplane is specially designed for beginners as a training airplane.

The airplane has adopted the exclusive protective device for the propeller. With the high strength EPP material for body, the plane will be intact even when it crashed. This is very suitable for the beginners to practice their skill.

There is built-in checkout system for low voltage protection. With MCU technology to check the voltage of the lithium battery, the low-voltage protection function will be activated when the voltage is lower than $6.4V \pm 0.2V$. However, the rudder still functions to allow the airplane to land safely by the player. The MCU low voltage protection function can be deactivated by pushing the throttle back to zero. The airplane can be operated by pushing the throttle again.

FCC INFORMATION AND WARNING

Caution :

Changes or modifications not expressly approved by the party responsible for compliance could void the user's authority to operate the equipment.

Compliance statement:

1: This device is verified to comply with Part 15 of the FCC Rules.

Operation subject to the following two conditions: (1) this device may not cause harmful interference, and (2) this device must accept any interference received, including interference that may cause undesired operation.

2: This equipment has been tested and found to comply with the limits for a Class B digital device, pursuant to Part 15 of the FCC Rules. These limits are designed to provide reasonable protection against harmful interference in a residential installation. This equipment generates, uses and can radiate radio frequency energy and, if not installed and used in accordance with the instructions, may cause harmful interference to radio communications. However, there is no guarantee that interference will not

occur in a particular installation. If this equipment does cause harmful interference to radio or television reception, which can be determined by turning the equipment off and on, the user is encouraged to try to correct the interference by one or more of the following measures:

- Reorient or relocate the receiving antenna.
- Increase the separation between the equipment and receiver.
- Connect the equipment into an outlet on a circuit different from that to which the receiver is connected.
- Consult the dealer or an experienced radio/TV technician for help.

Product Warning

NE R/C 771B Xtra 300 is not a toy. Children under 14 years old are strictly forbidden from flying this airplane.

You must fly this airplane safely.

When flying or preparing the airplane for flight you should strictly adhere to the instructions. Ensure that yours and other people's hands, and face are kept away from the rotating parts.

Always use the airplane outdoor areas that are free of wind. Never fly close to or above others.

Always unplug the airplane battery before turning off the transmitter when the airplane is stopped.

LiPo Battery Safety Guidelines and warning

Airplane uses a lithium polymer battery. Always comply with operating instructions for the lithium polymer battery to avoid accidents such as combustion or explosion.

Always use a genuine Nine Eagles™ charger and power adapter designed for this airplane.

Always unplug the charger and adapter from the electrical outlet after completion of each charge.

Never overcharge the battery, avoid use under direct sunlight or near fire. Ensure the battery is kept dry.

Never store or transport the battery with metal objects.

Never disassemble the battery.

Never use wet hands when in contact with the charger, battery or power adapter.

When you fly the airplane, keep distance from other electrical equipment, magnetic objects, wireless devices, etc, to avoid interference and accidents.

If you are unsure of how to charge the battery included with this product, please seek the advice of your local hobby shop.

Charging and discharging the batteries has the potential for fire, serious injury to persons and damage to property. The user of this battery agrees to accept responsibility for all such risks. Nine Eagles™, its affiliates, distributors, and retail partners can not control the use, application, charging or installation of this product and shall not be held responsible for any accident, injury to persons, or damage to property resulting from the use of this product. Read all safety guidelines, charging instructions, and battery disposal instructions before using batteries. Store battery packs out of the reach of children and pets. Children under the age of 18 must be supervised by a responsible adult. Children under 14 years of age should not be permitted to use this product under any circumstances. This product contains chemicals known to the state of California to cause Cancer, Birth Defects and other Reproductive Harm.

Li-PO BATTERY WARRANTY

This product is warranted against defects in original material and workmanship only. No term warranty is offered with this product. In no case shall Nine Eagles™ liability be greater than the actual retail purchase price of this product.

SPECIFIC SAFETY GUIDELINES

1. Store in a fire proof container and charge on an open fire proof surface.
2. Charge in a protected area devoid of combustibles. Never leave the charging process unattended.

3. In the event of damage carefully remove the battery to a safe place to observe for at least half an hour. Damaged batteries are likely to explode. Never attempt to charge a damaged battery, no matter how slight the damage is. Dispose of damaged batteries as the instructions below.
4. Only use the Nine Eagles balanced charger designed for this battery. Never use chargers designed for Ni-CD batteries. If the batteries show any sign of swelling, remove them to a safe place outside as they could erupt into flames.
5. MOST IMPORTANT – Never plug in a battery and leave to charge overnight. Serious fires have resulted from this practice.
6. Do not attempt to make your own battery packs from individual cells.

If the battery pack involved in a crash or is otherwise damaged

1. Remove the pack from the model.
2. Inspect the pack for damage to the wiring or connections
3. If necessary, disassemble the pack and dispose of any damaged cells

Disposal of Li-PO batteries

1. Put the pack in a safe open area and connect a moderate resistance across the cell terminals until the cell is completely discharged.
CAUTION: The pack may get extremely hot during the discharge
2. Puncture the plastic envelope and immerse in salt water for several hours.
3. Place in your regular rubbish bin.

Note on Lithium Polymer Batteries



Lithium Polymer batteries are significantly more volatile than alkaline or NiCd/NiMH batteries used in RC applications. All manufacturer's instructions and warnings must be followed closely. Mishandling of LiPo batteries can result in fire. Always follow the manufacturer's instructions when disposing of Lithium Polymer batteries.

Instructions for Disposal of WEEE by Users in the European Union



This product must not be disposed of with other waste. Instead, it is the user's responsibility to dispose of their waste equipment by handing it over to a designated collections point for the recycling of waste electrical and electronic equipment. The separate collection and recycling of your waste equipment at the time of disposal will help to conserve natural resources and ensure that it is recycled in a manner that protects human health and the environment. For more information about where you can drop off your waste equipment for recycling, please contact your local city office, your household waste disposal service or where you purchased the product

Specification

Model No:	NE R/C 771B
Wing span:	501mm
Overall Length:	445mm
Flying weight:	95g
Power System:	N60 Motor
Battery:	7.4V 250mAh Li-Po
Height:	172mm

Product List

Description	QTY
Airplane	1
Transmitter	1
Power Adapter	1
Li-Po Battery	1
Charger	1



⑦

www.NineEagle.com

Instruction for assembling the airplane

Please install the tail wheel first if you own a NineEagles's NE771B in alum case.

1. Insert one end of the steer wing of tail wheel into the coupled hole which is horizontal to the tail wing. Then lock the steel wing into the slot of the tail wheel holder. (See figure 1)

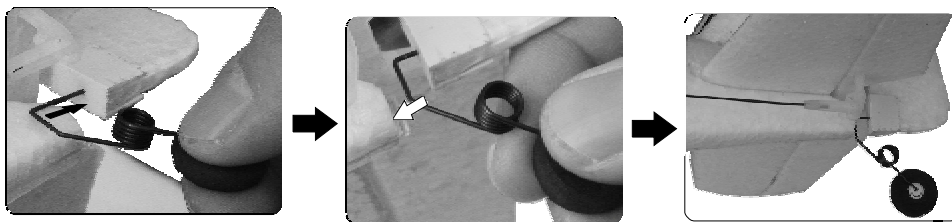

(figure 1)

2. Fit the wing on the top of the plane body. Make sure the wing is exactly at the center of the body. Contact airon plug with receiver plug
The wing is fixed by pins at the front and by screw at the back
(See figure2)



(figure 2)

4. Fit the propeller in the propeller protector. (See Figure 3)

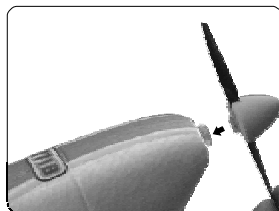

(figure 3)

5. Fit the front landing gear in the front body, make sure the steering wing of front landing gear forward inclined.(See Figure 4)

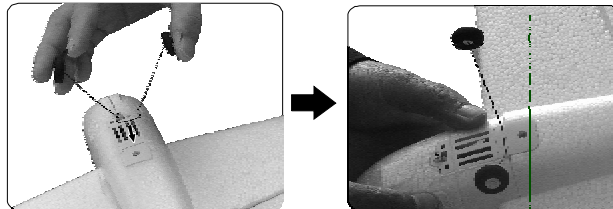

(figure 4)

Battery Mounting, Charging and Maintenance

1. Battery Recharging

The use Nine Eagles Li-PO battery to fly your recommeended.This Li-PO battery will deliver the best flight performance and flight time,as it is designed for airplane.

Please read the label on the battery,then recharge as following:

- 1) Insert the adapter in the Nine Eagles Balanced Charger(step1).
- 2) Plug the adapter into the power outlet (step2).
- 3) Insert the3 lead connector on the Li-PO Battery into the balanced Charger (step3).
- 4) The red light indicates power on.When the green light flashes,it is charging.When the green light it on permanently. charging is complete and the battery should be removed from the charger at this point.
- 5) In order to charge safely and fast,please use only Nine Eagles.
- 6) Please observe the battery when charging.
- 7) Please keep the battery away from cources of heat at all times .Do not cover the charger or battery.Always keep them ventilated.
- 8) Ensure charging is a fire proof location.
- 9) Always unplug the charger and power adaptor from the electrical outlet after completion of each charge.

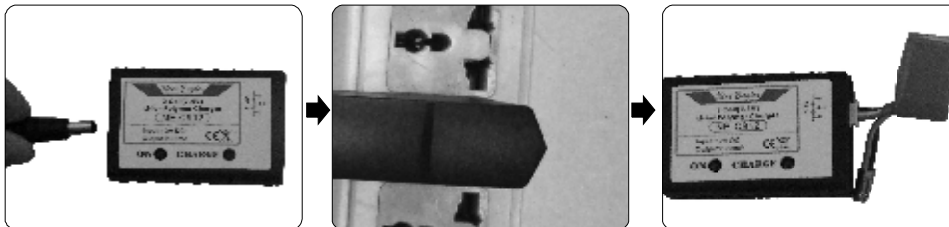

Transmitter Control Identification

Model

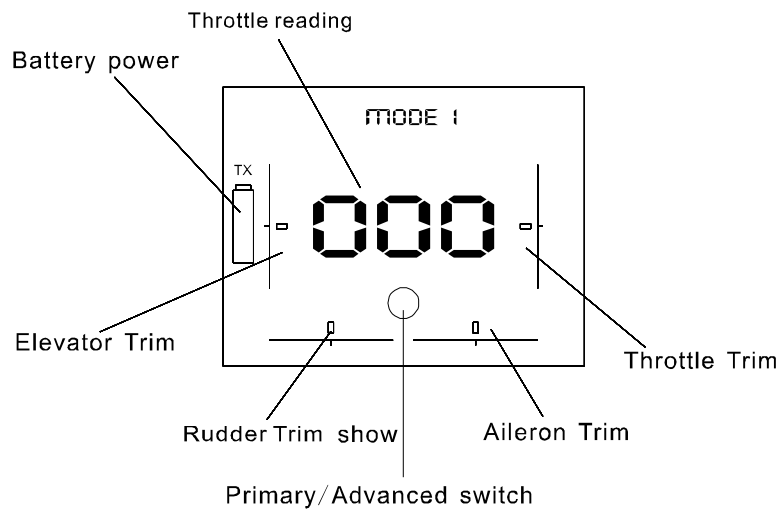
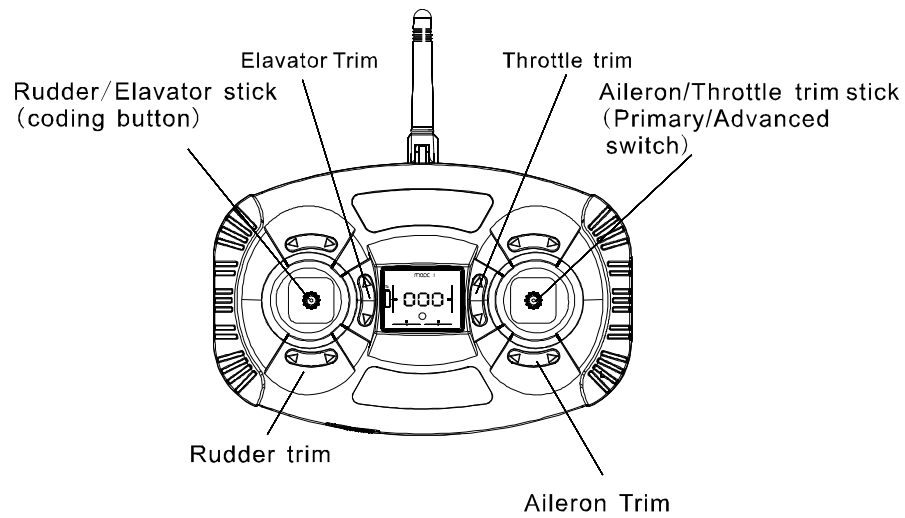

Mode2

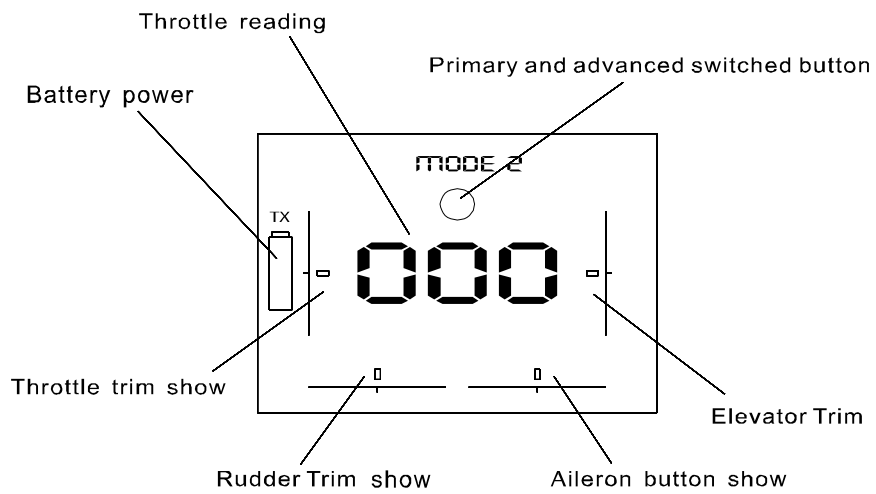
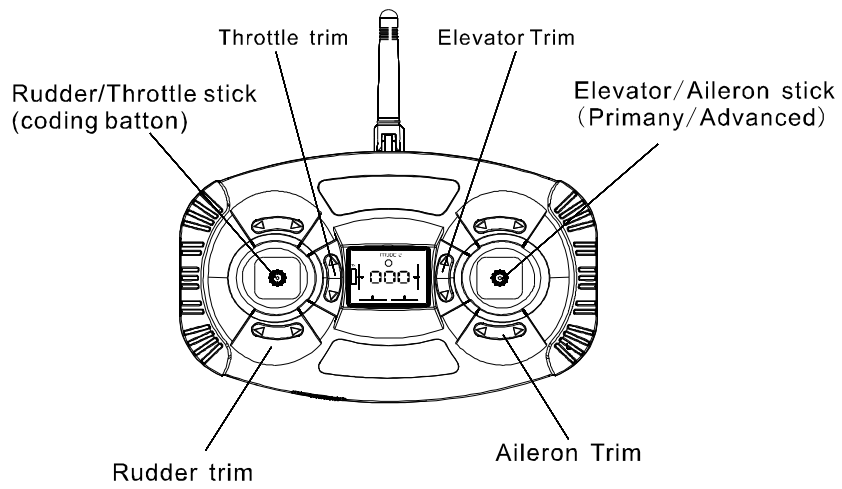

Preparation before fly

1. Take off the battery box cover of remote controller
2. Install 4 pieces of AA batteries
3. Turn on the power, check if LCD screen has readings:
4. Open the battery box cover of the airplane (See figure A). Connect the two plugs of the battery together (See figure B). Put the battery in the box (See figure C). Close the box with cover (See figure D)

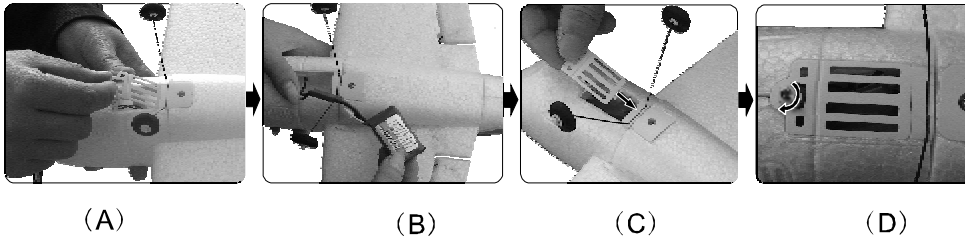

- 5 Set up the battery and make sure the tail set and the body surface is smooth and flat. Please adjust the corresponding position of Springy slot if they are not smooth or flat enough (Note: The product has already been adjusted before leaving the factory in the common place .) See the following photos.

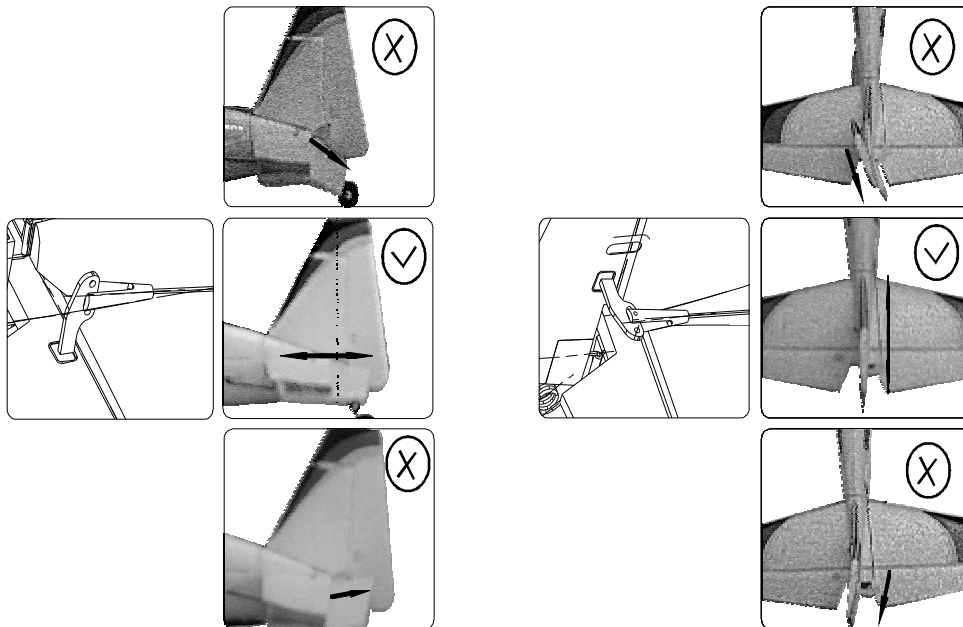

Pre-flight check

Make sure all trim buttons are in the middle position and the throttle stick is at its lowest position before fly.

Make sure airplane is in a horizontal path against wind before casting.

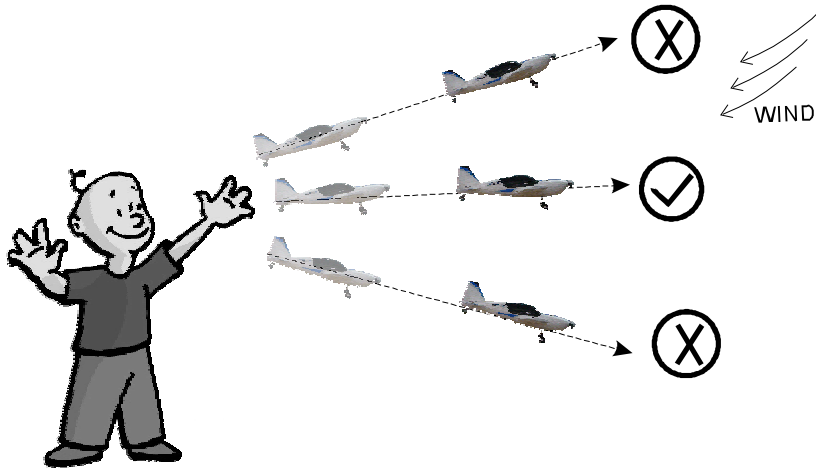

Throttle trimming

MODE 2

If the propeller runs when no throttle stick input is given, or it doesn't run when the throttle stick input is given, an adjustment for the throttle trim system is required. Push the propeller throttle stick downwards until the propeller stops when the propeller runs without throttle stick input.

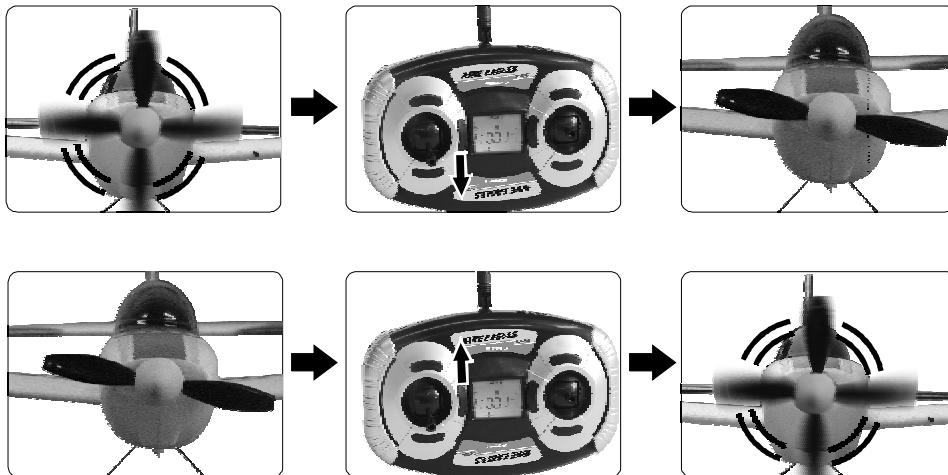

Elevator trimming**MODE 2**

When the airplane tilts upwards and downwards during fly, an adjustment of rudder is required. If the airplane tilts downwards, push the trim button downwards until it doesn't tilt. If the airplane tilts upwards, push the trim button upwards until it doesn't tilt.

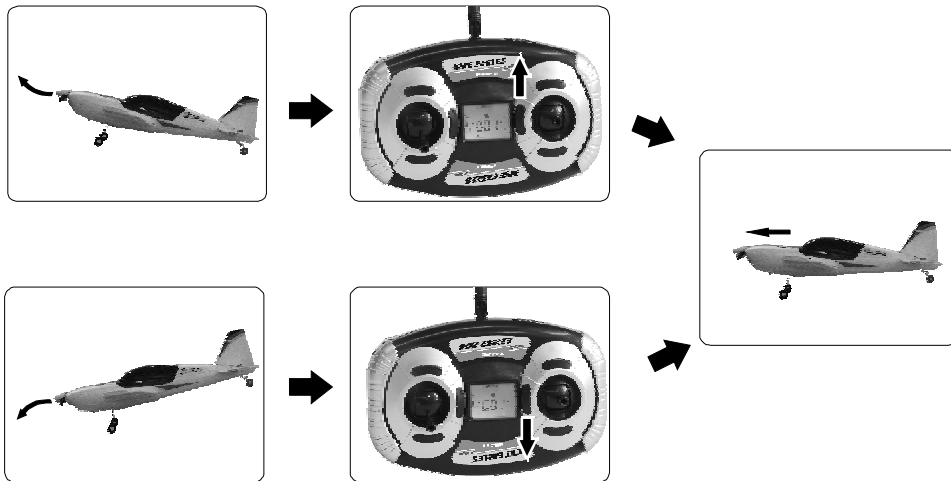
**Direction trimming****MODE 2**

If the airplane makes left or right hover, even such order is not given in its flight, the following adjustment of direction is required. If the airplane hovers left, push the direction trim button to the right until it flies forwards. If the airplane hovers right, push the direction trim button to the left until it flies forwards.

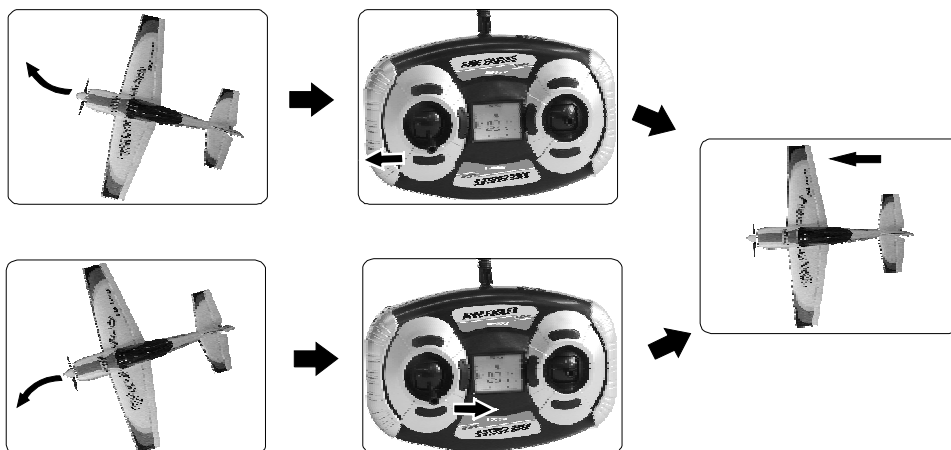







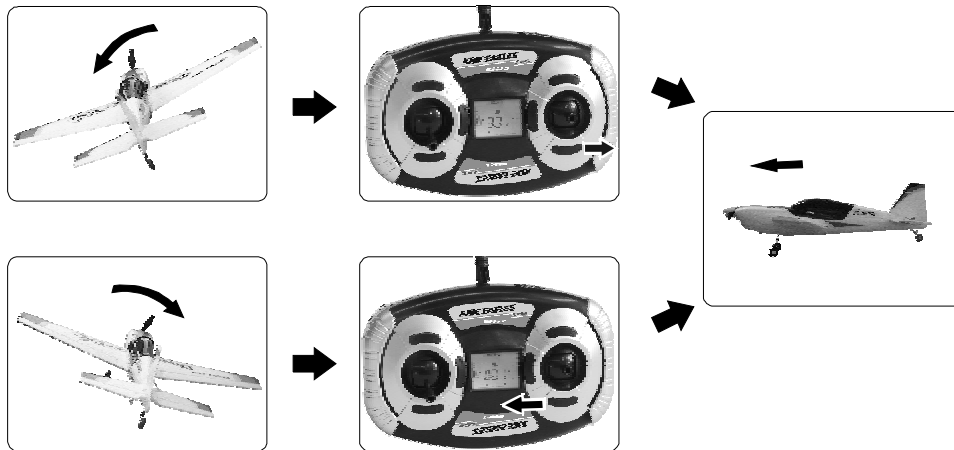









Aileron trimming

MODE 2

If the airplane left or right incline , even such order is not given in its flight, the following adjustment of aileron is required. If the airplane incline right, push the aileron trim, to the left whtil it flies forwards right . If the airplane incine left, push the aileron trim button to the right until it flies forwards.



Mode 1

Throttle	Elevator	Rudder	Aileron
 Acceleration 	 Up 	 Right movement 	 
 Decelerate 	 Down 	 Left movement 	 

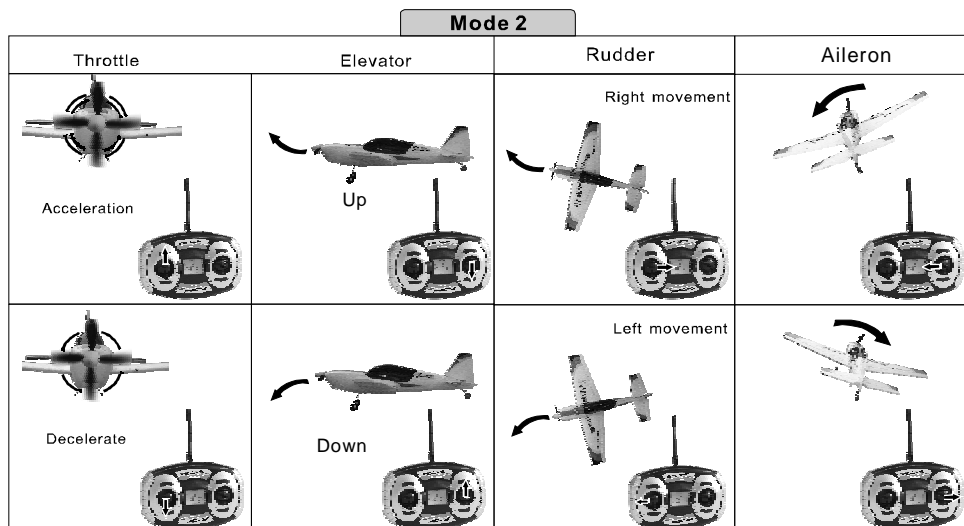

Flying field

The flying field selected must be suitable for flying. No obstacles are allowed when flying the plane in the room. The plane must be flown in open area. Please keep the airplane away from trees, electrical cables and other obstacles. Flying over the people is prohibited.

Fly practice

Turn on the transmitter in accordance with the manual. Turn on the power of the airplane. After the airplane is adjusted, check the servo before fly.

1. Check the wind direction before fly. The airplane is supposed to take off or land towards the wind.
2. Push the throttle stick and throw the airplane horizontally.
3. Adjust the throttle and direction stick to fly the airplane stably. The beginner is not supposed to fly the airplane either too high or too far. If the airplane doesn't fly stably, an adjustment for the airplane is required before flying it

4. The beginner shall use the controllers gently. Suddenly flying the airplane up or down is not allowed.

5. The airplane shall be placed on the flat ground and in the proper direction before taking off from ground. Accelerate the airplane in a straight line by increasing the throttle stick input.

6. In order to learn the flying skill better, it is suggested that the beginner shall use the small rudder to control the airplane. The players can turn to big rudder when they become more skilled after enough training.

Notify Items

1). Please stop flying when you feel the battery is running out.

2). Always remove the airplane battery immediately and then turn off the transmitter when you finish flying.

3). When the airplane has crash onto some objection, please loose the throttle ASAP to avoid any damage (please check the spare parts ASAP when the crash happened. You can purchase the spare parts from the Nine eagles local distributor when you change the broken spare parts).

4). If you do not use the airplane for a long time, please keep 50% power of the Li-PO Battery, and take the batteries out of the transmitter.

Miscellaneous

Repairs and Maintenance

A wide range of genuine Nine Eagles™ parts and accessories are available from your local Nine Eagles supplier. Please review the enclosed Parts List Brochure to see what is available.

Clubs and Associations

Nine Eagles™ supports the model flying community around the world. We encourage you to meet new friends and learn to fly through your local club or association. Contact them through your local Hobby Retailer.

Troubleshooting

For the latest troubleshooting advice, please contact your local hobby store

Feedback

If you have any suggestions for modifications or future designs, we would like to hear from you. Please free to contact us at sales@nineeagle.com

NOTHING FLIES LIKE NINE EAGLES



SHANGHAI NINE EAGLES ELECTRONIC TECHNOLOGY CO.,LTD

Factory: MaLu industrial zone. Jia Ding district.
shanghai. 201801 PR. China

Tel: 0086-21-52919366

Fax: 0086-21-52919361

<http://www.nineeagle.com>

E-mail: sales@nineeagle.com